

# LSM-81

## GSM/LTE Alarm Module and RTU

### Version 1.44

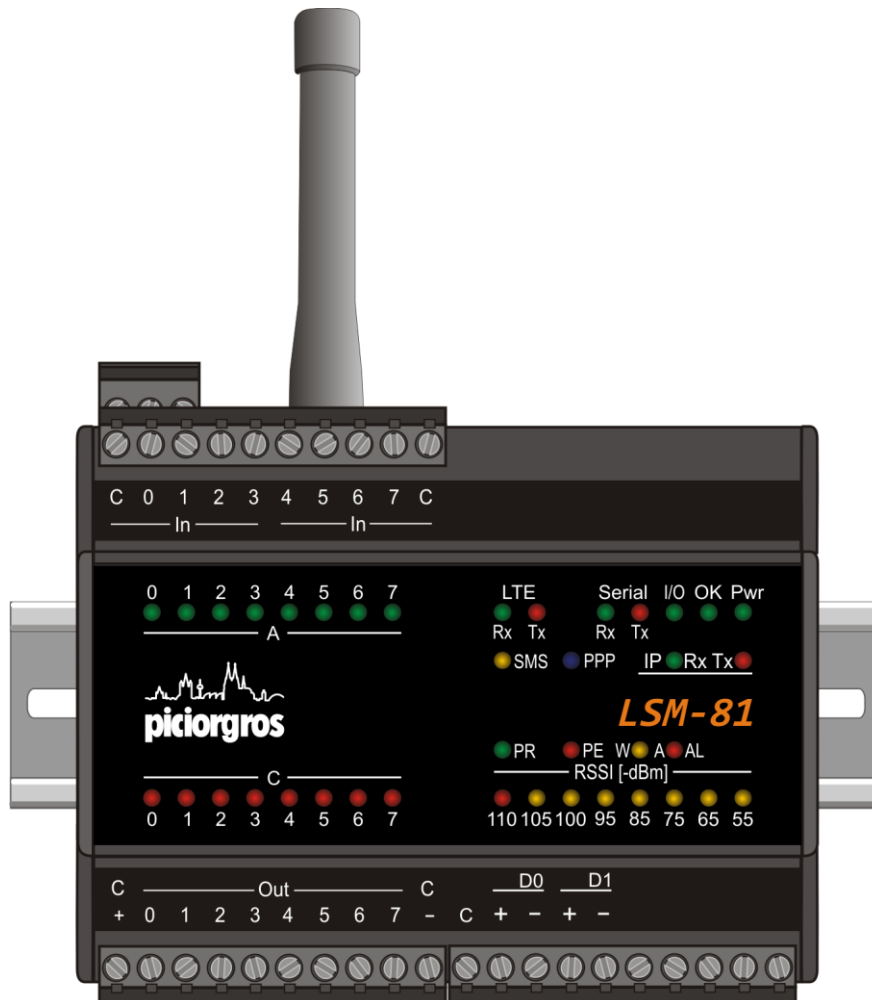

Funk-Electronic Piciorgros GmbH  
Claudiastrasse 5  
51149 Cologne  
Germany

## Table of Content

<b>1</b>	<b>INTRODUCTION.....</b>	<b>5</b>
1.1	Overview .....	5
1.2	Safety Precautions .....	5
1.3	Disclaimer.....	5
1.4	Functions and Features.....	6
1.5	Hardware Options.....	6
1.5.1	RS-422/485 for serial interfaces .....	6
1.6	Software-Optionen .....	7
1.6.1	PicoLogo – embedded User Application Interface .....	7
1.7	Document Changes .....	7
<b>2</b>	<b>CONNECTIONS AND HARDWARE INSTALLATION .....</b>	<b>8</b>
2.1	Mechanical Details.....	8
2.1.1	Dimensions.....	8
2.1.2	Mounting.....	9
2.1.3	Dismounting.....	9
2.2	Electrical Connections.....	10
2.2.1	Connection diagramm.....	10
2.2.2	Power Supply Input.....	10
2.2.3	Serial Interface .....	11
2.2.4	Ethernet Interface.....	12
2.2.5	Extension Port for additional I/O modules .....	12
2.2.6	Connecting the I/Os .....	13
2.2.7	Connecting the Antenna .....	14
2.3	LED Functions.....	15
2.3.1	OK LED: Flashing Code Error detection.....	18
2.3.2	Other LED Codes .....	18
2.4	Reset to factory default .....	19
2.4.1	Reset via Web Server .....	19
2.4.2	Reset via Configuration Button.....	19
2.5	Temporary reset to default IP address .....	20
<b>3</b>	<b>STARTING UP THE LSM-81 .....</b>	<b>21</b>
3.1	Requirements.....	21
3.2	Accessing the embedded web server .....	22
3.2.1	Navigation using the Menu.....	24
3.2.2	Applying changes .....	24
3.2.3	Requesting Restart of the Device .....	25
3.2.4	Session timeout and page reload .....	25
3.3	Configuration of SIM PIN and own phone number .....	26
3.4	Inserting the SIM card.....	27
3.4.1	Removing the SIM card .....	28
3.5	First registration to the mobile network .....	29
3.5.1	Requesting the cellular radio status in the Webserver .....	31
3.6	Basic configuration of the device.....	32
<b>4</b>	<b>ALARM MODULE FUNCTIONS .....</b>	<b>34</b>
4.1	Description of Functions .....	34

4.1.1	Alarming Procedure .....	34
4.1.2	Acknowledging an alarm.....	35
4.1.3	“Acknowledgement notification” .....	36
4.1.4	Triggering an Alarm via PicoLogo.....	36
4.2	Alarm Configurations .....	37
4.3	Phone book .....	38
4.4	Configuration of digital alarm blocks.....	39
4.5	Configuration of analog Alarm blocks.....	42
<b>5</b>	<b>ONLINE-RTU-FUNCTION .....</b>	<b>46</b>
5.1	Requirements and Functioning.....	46
5.1.1	Requirements.....	46
5.1.2	Functioning .....	46
5.1.3	Data Usage .....	47
5.2	Setting the LSM-81 up for a connection to the internet .....	48
5.2.1	Internet connection monitor .....	50
5.3	Setting up the connection to an MDP-810 .....	52
5.3.1	MDP-Connection Monitor.....	54
5.4	MoP Push (Request polling at input change).....	55
5.5	Device information on connection status and data usage .....	57
<b>6</b>	<b>SUPERVISION VIA MMI.....</b>	<b>59</b>
6.1	Basic configuration of the MMI access .....	59
6.2	Format of MMI Commands.....	59
6.2.1	Multiple commands in one SMS .....	60
6.3	MMI Commands.....	61
6.3.1	A – Polling the binary input of the first port.....	61
6.3.2	AB=? – Poll a binary input .....	61
6.3.3	AI=? – Polling an analog input.....	62
6.3.4	C – Polling or setting a binary input of the first port .....	63
6.3.5	CD=? – Polling binary outputs.....	63
6.3.6	CP – Set or request value of cost protection .....	64
6.3.7	DI – Polling binary input.....	65
6.3.8	DO –Polling or setting a binary output .....	66
6.3.9	PU – Pulse output of binary outputs.....	67
6.3.10	Q – Enforce or suppress Acknowledgements .....	67
6.3.11	R – Request register value .....	67
6.3.12	RF – Requesting field strength .....	68
6.3.13	SN=? – Request Serial Number .....	68
6.3.14	Z=1 – Adding Time Stamp .....	68
6.4	Remote controlling between LSM-81s using MMI .....	69
<b>7</b>	<b>RTU FUNCTIONALITY .....</b>	<b>72</b>
7.1	Configuration of Inputs and Outputs.....	73
7.1.1	Virtual analog inputs and outputs, Monitoring .....	73
7.1.2	Delay of binary inputs of the LSM-81 .....	75
7.1.3	Configuration of Counters .....	76
7.2	Access via MODBUS protocol.....	77
7.2.1	Supported MODBUS Commands .....	79
7.2.2	MODBUS-Register Addresses.....	80

7.2.3	Special MODBUS Registers .....	82
7.2.4	MODBUS coil and input commands.....	83
<b>8</b>	<b>OTHER FUNCTIONS.....</b>	<b>84</b>
8.1	Serial interface .....	84
8.2	IP application interface .....	87
8.3	SMS Gateway (#-Command-Mode) .....	89
8.4	Device Information and Security .....	90
8.5	Setup of Ethernet Address .....	91
8.6	Other Configuration Options .....	92
8.6.1	Changing the password.....	92
8.6.2	Configuration of the Loggers and the Device Options.....	93
8.6.3	Restart and setting back to factory default .....	95
8.6.4	Event Logger.....	95
<b>9</b>	<b>PICOLOGO® APPLICATION PLATTFORM .....</b>	<b>96</b>
9.1	PicoLogo-Configuration.....	96
9.1.1	Contact Table .....	98
9.1.2	Parameter Table.....	99
<b>10</b>	<b>TROUBLESHOOTING AND ADMINISTRATION.....</b>	<b>100</b>
10.1	Saving and restoring a configuration .....	100
10.1.1	Downloading the configuration of an LSM-81.....	100
10.1.2	Restoring a Configuration .....	102
10.2	Collecting Support Logs.....	103
10.2.1	UDP Logging .....	106
10.2.2	Automatic splitting of Log File .....	106
10.3	Updating the Firmware .....	107
10.3.1	Preparation and Setup .....	107
10.3.2	Update Procedure.....	107
10.3.3	Multilingualism .....	109
<b>11</b>	<b>TECHNICAL SPECIFICATIONS.....</b>	<b>110</b>

# 1 Introduction

---

## 1.1 Overview

This document contains information about installation, settings, and operation of the Alarm module LSM-81. Additional information is also available over the Internet, at the website <https://piciorgros.com>. This includes practical guidance relating to antenna selection and installation, operating range, expansion modules, software support, etc.

## 1.2 Safety Precautions

This equipment transmits radio waves. Under certain circumstances, these radio waves could be harmful to any living being or electronic equipment near it. Care should be taken to ensure that the radio and antenna systems are installed and commissioned only by trained persons.

This radio equipment should not be used in life support systems or in safety systems without our prior written permission.

## 1.3 Disclaimer

We have carefully checked the contents of this document, and the hardware and software described in it, for compatibility. We cannot however exclude possibilities of deviations and cannot guarantee complete conformity of the document with the equipment it describes. If any corrections or improvements are to be made, they will be taken into consideration in the next edition of this document.

Important instructions are marked by the expressions "Important", "Note" or "Caution!". These should be carefully observed. Explanations regarding these precautions can be found in the website [www.piciorgros.com](http://www.piciorgros.com), in the Login Area pages.

## 1.4 Functions and Features

The LSM-81 is an alarm module, which operates in GSM and LTE networks and which can send operating conditions via its digital and analog inputs as alarm messages via SMS.

Twenty-four binary and sixteen analog message blocks are available. Each single one can be configured with a unique alarm text and can have individual trigger and alarming preferences.

The alarm chain can contain up to twenty-five members and can enforce an optional acknowledgement.

The device can be controlled via SMS by using the MMI (Man-Machine-interface) functions. This is how SMS control functions can be initiated via the binary outputs or the status of the inputs can be retrieved.

The basic LSM-81 has eight binary inputs, eight binary outputs and two analog inputs (0/4-20mA). These can be extended by using expansions modules to up to twenty-four digital inputs and outputs as well as ten analog inputs for embedded alarm functions.

Up to two MDP-810 radio servers can be connected to an LSM-81 via LTE. The LSM will function as a regular outstation and can also be used in mixed operation with other technologies (e.g. TETRA). The LSM-81 can be accessed from the MDP-810 via a public cellular network to gather measurements and also to manage its outputs.

## 1.5 Hardware Options

### 1.5.1 RS-422/485 for serial interfaces

The standard interface of the LSM-81 is the RS-232 interface, which is used for locally accessing the device via the MODBUS/RTU protocol or for sending and receiving SMS via # commands.

Optionally the LSM-81 can have an RS-422/485 interface.

## 1.6 Software-Optionen

### 1.6.1 PicoLogo – embedded User Application Interface

The PicoLogo option is a powerful User Application Interface that can be used similar to a Micro PLC to generate Alarms, Text-Messages, M2M-Communication or to monitor and supervise digital or analog values.

An additional graphical editor for developing PicoLogo applications is also available.

## 1.7 Document Changes

The history of this documentation is listed below:

Firmware Version	Document Version	Comments / Changes
1.02	1.00	First Release Version
1.10	1.10	Multilingual adaptation, English and German firmware available. Screen shot in technical documentation replaced with German screen shots
1.20	1.20	PicoLogo available New function: Subscribers that receive alarms will also be informed about an acknowledgement Each alarm block can also be triggered by a virtual input from the PicoLogo platform
1.30	1.30	The selection of the alarm block which should be configured happens now via a dropdown field. The description was updated accordingly.
1.40	1.40	New Function „Online Operation with MDP-810” added with corresponding descriptions. Changes made to menu in web server PicoLogo menu added to documentation
1.44	1.44	Added hint that the LSM-81 now tries to get its own phone number from the SIM card

Software Release Notes are distributed with firmware packages.

## 2 Connections and Hardware Installation

---

### 2.1 Mechanical Details

The dimensions of the LSM-81 housing conform to DIN 43880, and therefore it can be mounted on a standard 35mm DIN rail [DIN EN 50022]. The LSM-81 has one serial interface for communicating via MODBUS/RTU with a locally attached device or by serving as an SMS-gateway (sending and receiving SMS via # commands). The serial interface is using a female DB9 connector.

On the lower side of the housing an RJ-45 connector for the Ethernet port is used for the configuration of the LSM-81.

On the upper side of units with embedded I/O, a RJ-45 connector is provided to connect PEM I/O expansion modules.

Also, on the upper side of the unit the plug-in terminal connector for the power supply (12-24 VDC +/-20%) and a SMA socket for the GSM/LTE antenna can be found.

The Mini SIM card is inserted into a push pull card reader on the left side of the device.

LED lamps on the front panel provide information about the operating condition of the unit: e.g., received LTE RF signal strength, error conditions, etc.

#### 2.1.1 Dimensions

The dimensions of the LSM-81 are as follows:  
108mm (6T) wide x 80mm high x 62mm deep  
All dimensions exclude connectors and antenna.

### 2.1.2 Mounting

The DIN-rail mounting clip is at the bottom of the Module. First the lower lip (spring-loaded) of the clip is engaged with the lower flange of the DIN rail, with the Module tilted downward slightly. The Module is then pushed upward (1) and rotated backward (2) until the upper lip of the clip snaps onto the upper flange of the DIN rail.

### 2.1.3 Dismounting

To dismount the Module, force it upwards (1), and then rotate its upper end outward (2) until the upper lip of the Module's clip disengages from the upper flange of the rail. Then move the Module down slightly to disengage its lower lip from the rail flange.

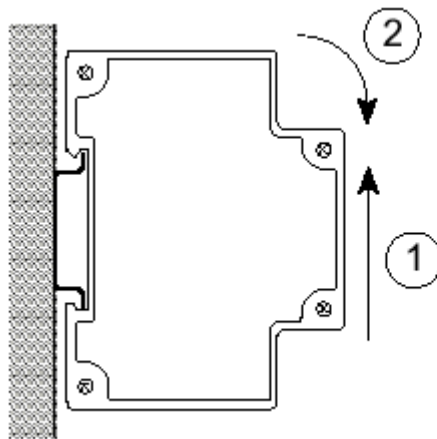

**Mounting**

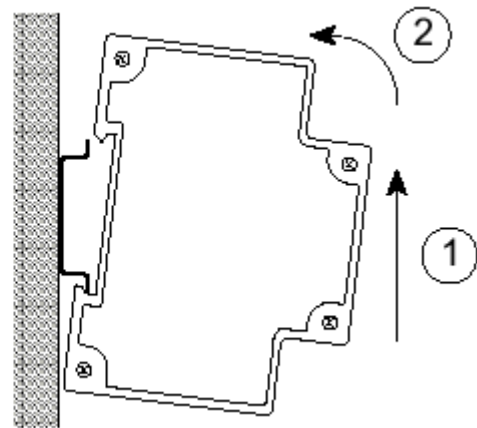

**Demounting**

## 2.2 Electrical Connections

### 2.2.1 Connection diagramm

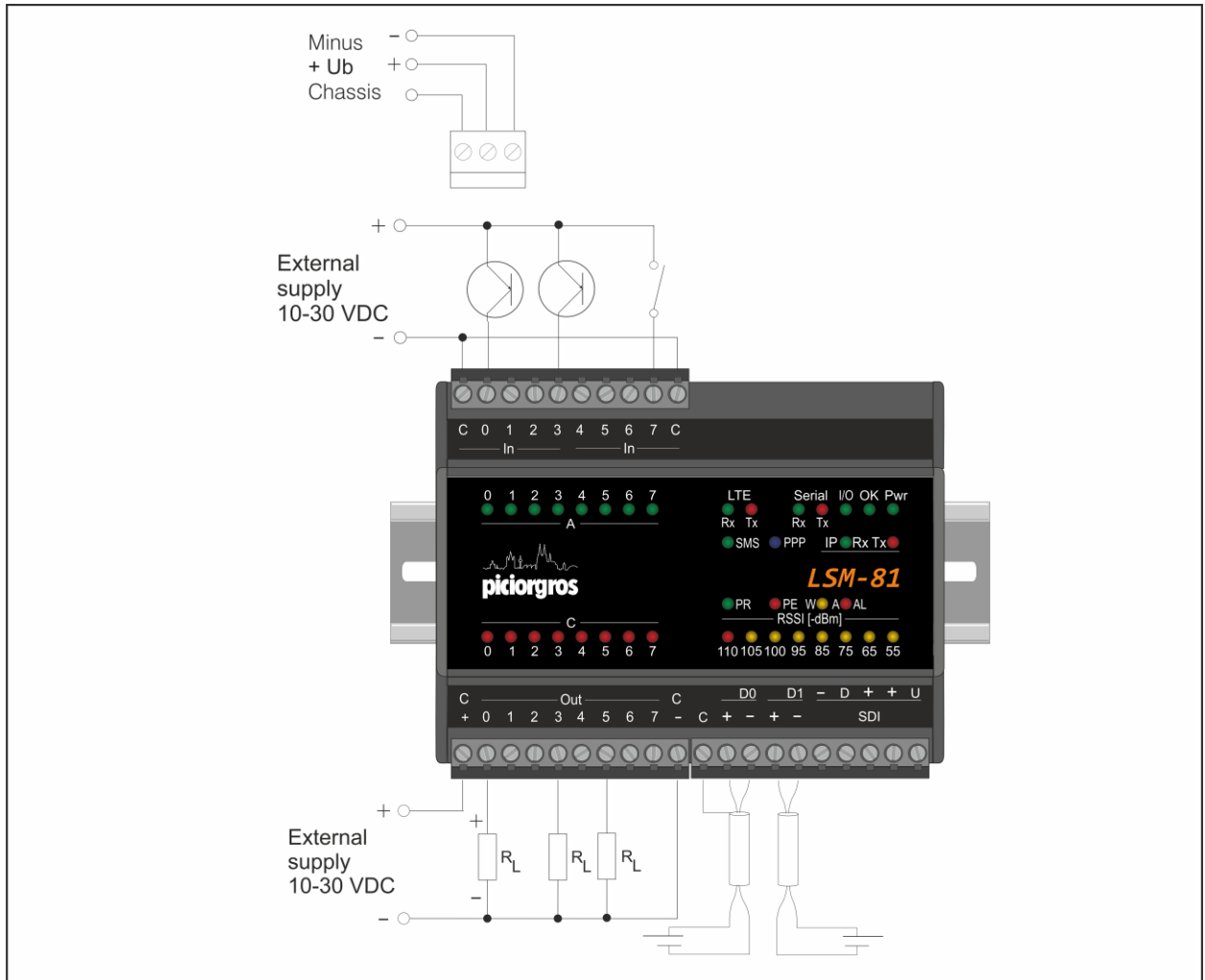

### 2.2.2 Power Supply Input

The required supply voltage (12-24 VDC +/-20%) is connected through 3-way screw terminal connector located on the upper side of the enclosure.

The terminals are assigned as follows (viewed from the front of the module, facing the front panel):

- Outer (left): Enclosure Ground (electrical earth)
- Middle: + 12 Volt to + 24 Volt (+/- 20%)
- Inner (right): GND, 0 Volt from Power Supply

### 2.2.3 Serial Interface

The LSM-81 has one serial data interface. This interface has a 9-pin D-sub connector on the upper side of the unit. The interface can be either RS-232 or user-selectable RS-422/485 (RS-422/485 must be initially ordered as this is a hardware option)

The following parameters are user adjustable: baud rate in the range 300 - 57600 bps, data word length 7 or 8 bits, odd / even / no parity, and 1 or 2 stop bits. The factory setting is 9600 bps, 8 data bits, no parity, 1 stop bit.

If a frame error is detected, or if the parity bit does not conform to the setting, the received data block is rejected.

Pin No.	Pin Assignment: RS-232	
2	TxD	Send data LSM-81 → peripheral
3	RxD	Receive data LSM-81 ← peripheral
4	DTR	Shorted to Pin 6
5	GND	
6	DSR	Shorted to Pin 4
7	RTS	Handshake LSM-81 ← peripheral
8	CTS	Handshake LSM-81 → peripheral

Pin No.	Pin Assignment: RS-422 (COM only)	
2	Y	Transmitter + (output)
3	Z	Transmitter – (output)
5	GND	
7	A	Receiver + (input)
8	B	Receiver – (input)

Pin No.	Pin Assignment: RS-485 (Hardware option)	
2	A	Transceiver +
3	B	Transceiver –
5	GND	

For the connection of the COM interface to a PC or PLC, use a standard 1:1 connector-terminated cable (9-pin D-sub male to 9-pin D-sub female).

### 2.2.4 Ethernet Interface

The Ethernet interface is provided via an RJ-45 socket on the underside the unit. This is a standard 10/100 Mbit/s interface. Two LEDs indicate the operating condition of this interface:

- Green LED: Lights up when an Ethernet network is connected (LINK)
- Yellow LED: Blinks when data transfer is taking place (DATA)

Network parameters such as IP address, net mask, and gateway address can be changed via the embedded configuration web server.

The interface supports Auto MDI-X, so the LSM-81 can be directly connected to a computer without the need of a crossover cable.

### 2.2.5 Extension Port for additional I/O modules

The number of inputs and outputs can be extended by attaching expansion modules to the LSM-81. Up to 16 expansion modules can be connected to the LSM-81. The connector is on the top side of the device. The expansion modules can be accessed by using the MODBUS RTU or MODBUS TCP protocol.

The following I/O modules are available:

PEM-16DI	16 digital inputs
PEM-32DI	32 digital inputs
PEM-16DO	16 digital outputs
PEM-32DO	32 digital outputs
PEM-16DIO	16 digital inputs and 16 digital outputs
PEM-08AI	8 analog inputs (0-20mA 4-20mA)
PEM-04AO	4 analog outputs (0-20mA 4-20mA)

I/O modules should only be connected to or disconnected from the LSM-81 when power supply is disconnected!

**Caution:**

Only twenty-four binary inputs, twenty-four binary outputs and ten analog inputs can be used for the internal alarm messages

Additional I/Os can be used for controlling purposes via the RTU functions, PicoLogo, MMI or MODBUS.

## 2.2.6 Connecting the I/Os

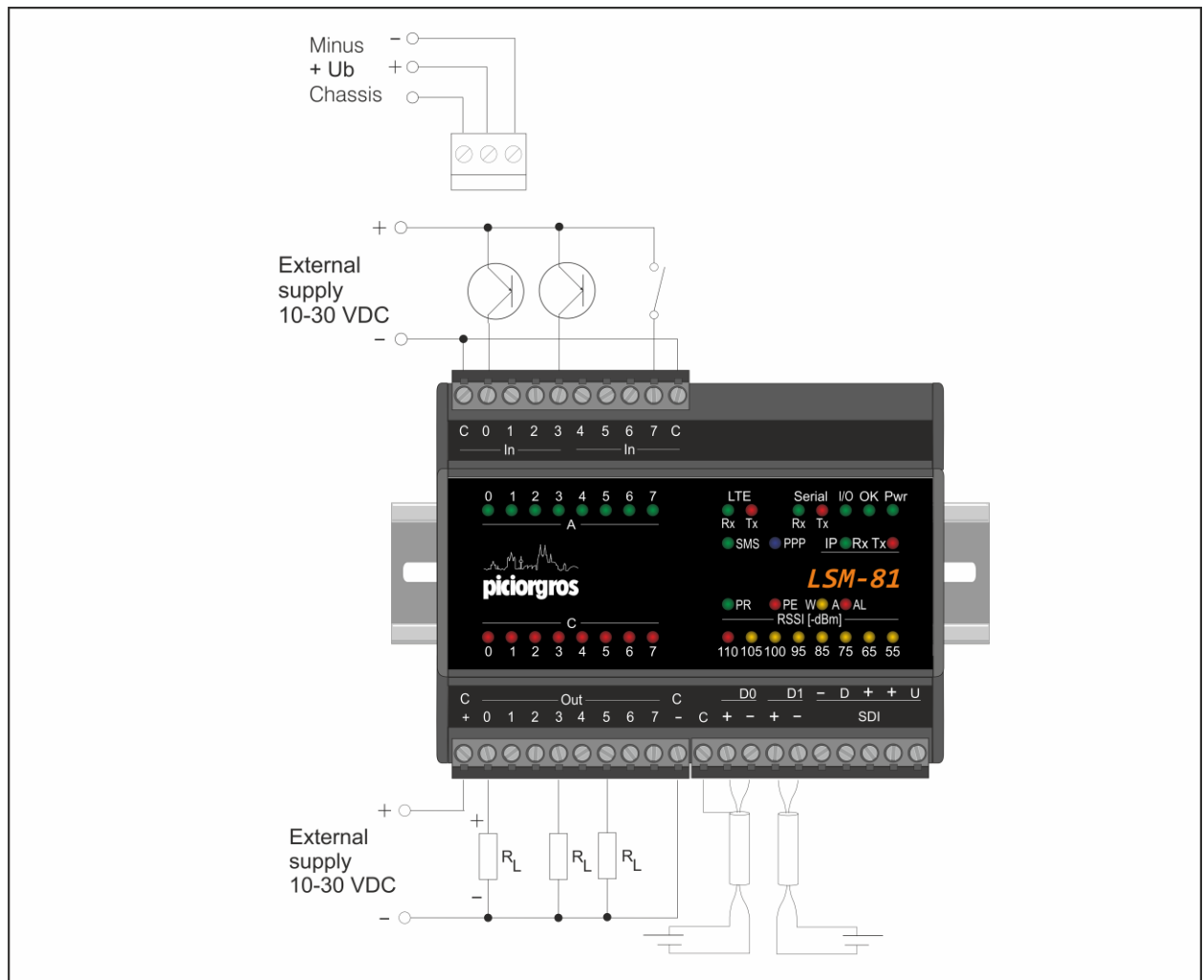

### Binary inputs:

The eight potential free binary inputs on Port A are divided into groups of four inputs each with the same reference potential "C". The inputs can be operated in any desired polarity within the voltage range of 12-24 VDC. If the "C"-input of a group is set to GND the individual inputs can be controlled with +12 to +24 Volt and vice versa. Once an input is active it will be indicated with the corresponding LED.

**Please note that the input voltage should not exceed 24V +20%!**

### Binary outputs:

The supply voltage for the binary outputs must be connected to the "+" and "-" terminal of port C. Active outputs will have the positive supply switched to the related terminal. The maximum load is 0.5A per outputs.

**Please note that the power circuit voltage should not exceed 24V +20%!**

**Analog inputs:**

The analog inputs are inputs for 0-20mA and has to be supplied externally. The polarity of the current flow has to be taken into consideration (the pins are indicated with “+” and “-“). The resolution is 12 Bit.

**Important: All I/Os are electrically isolated!**

**2.2.7 Connecting the Antenna**

The GSM/LTE antenna is connected to the LSM-81 via an SMA connector. The use of an external antenna is recommended when the LSM-81 is mounted into a cabinet.

The use of whip antennas within cabinets is not recommended, as the RF transmission can influence sensitive equipment in the cabinet. In worst cases, switching power supplies can have voltage fluctuations when exposed to nearby RF transmissions.

### 2.3 LED Functions

Groups of LED lamps on the front panel of the LSM-81 indicate the operating condition, the GSM/LTE field strength, and error conditions if any. Specific LED functions are described below.

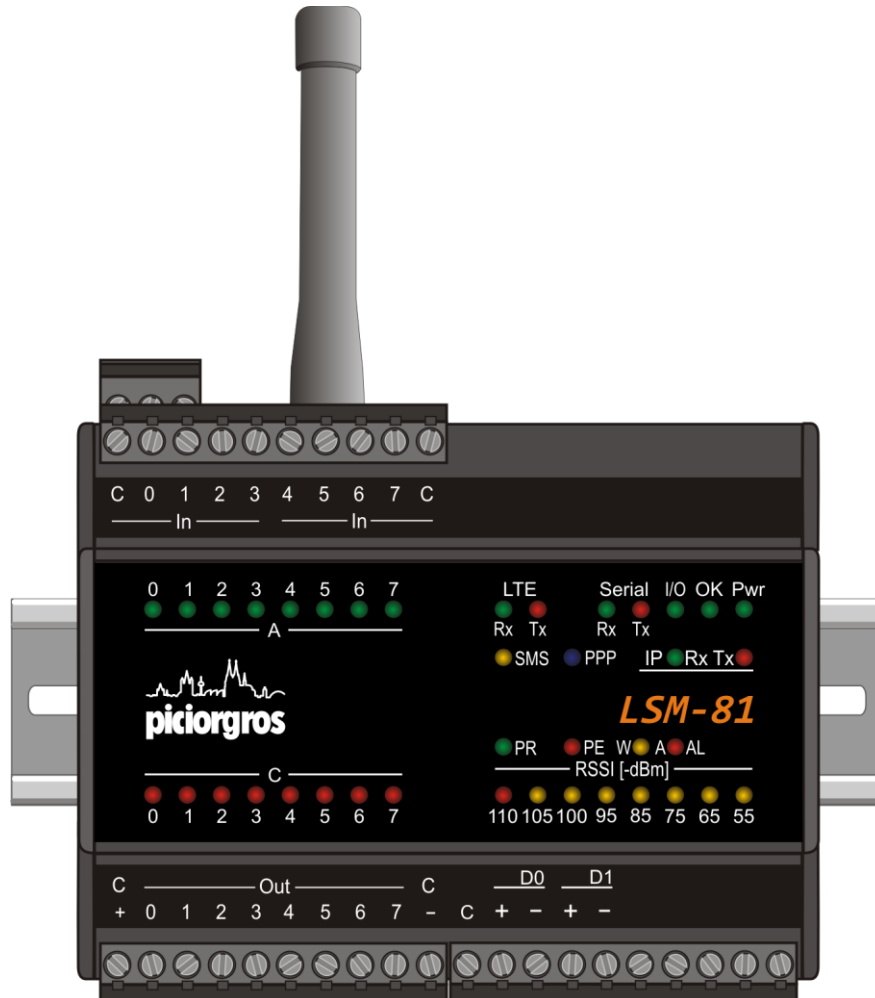

LED	Function
Pwr	Indication of operating voltage
OK	Indication of operational readiness (LED on), indication of error codes (various types of flashing)  A 1:1 flashing indicates that the LSM-81 has been forced to the pre-configured IP address 192.168.0.199/20. This mode can be changed by pressing the small configuration button (approx. 1 second) on the backside of the device with the help of a paper clip.
I/O	LED on when at least one PEM expansion module is connected to the device.  Flashing LED indicates I/O error. In this case all outputs are forced into a secure state (off).
Serial Tx	Indicates transmission of data via the serial interface
Serial Rx	Indicates reception of data via the serial interface
LTE Tx	LED on when data or SMS are sent via the GSM/LTE network
LTE Rx	LED on when data or SMS are received via the GSM/LTE network
SMS	Quick flash when SMS is sent or received
PPP	Flashes when IP data transmission is established  LED on when IP data connection (PDP context) is active and the device is ready to send and receive IP data.
IP Rx	LED on while LSM is receiving data via the Ethernet interface
IP Tx	LED on while LSM is sending data via the Ethernet interface
PR	Indicates that a PicoLogo application is executed (RUN-Mode)
PE	LED on when a PicoLogo application shows an error. In this case the application is not executed.
AL W	LED on when at least one alarm block was triggered but has not been activated yet (Alarm Waiting)
AL A	Indicates that at least one alarm block is in alarm state (Alarm active)  Once the cost control has reached its daily limit, the LED will flash periodically (if off before) or vice versa to signalize this state.

LED	Function
RSSI	<p>Receiving field strength of the mobile signal</p> <p>The red LED has a special function:</p> <p>During operation it is only steadily on when the field strength drops below 100 dBm</p> <p>During the initialization phase the red LED indicates the progress:</p> <ul style="list-style-type: none"> <li>• 1 x Flash – Pause Waiting for LTE Modem to start up</li> <li>• 2 x Flash – Pause Software initialization LTE-Modem</li> <li>• 3 x Flash – Pause Waiting for SIM card to be ready</li> <li>• 4 x Flash – Pause SIM Card ready and unlocked – remaining initialization</li> </ul> <p>Following other conditions are indicated by the red LED:</p> <ul style="list-style-type: none"> <li>• Slow Flashing (1:1) Modem initialized and searching for GSM/LTE-network (not yet registered)</li> <li>• Fast flashing (1:1) SIM card error. Possible reasons: <ul style="list-style-type: none"> <li>- SIM Card not installed</li> <li>- SIM Card cannot be read</li> <li>- Wrong PIN Number</li> <li>- SIM Card is locked</li> </ul> </li> </ul>
Port A	<p>The green LEDs show the condition of the respective binary input. The LED is on when the input is active.</p>
Port C	<p>The red LEDs show the condition of the respective binary output. The LED is on when the output is active.</p>

### 2.3.1 OK LED: Flashing Code Error detection

The OK LED is permanently green in standard operation. The LED starts flashing in specific patterns if errors occur.

Flashing Code	Type of Error
LED is off	The stations CPU is faulty or not ready for operation
No Flashing, LED permanently on	Ready for operation, no error
Flashing with a 1:1 cycle	The device is in programming mode set to IP address 192.168.0.199/20, regardless of the configured Ethernet IP address
Long Flash – short Flash alternating	The device is performing a firmware update
4 x Flashing - Pause	The LTE unit of the device is dysfunctional

### 2.3.2 Other LED Codes

Flashing Code	Type of Error
All LEDs flashing rapidly after power on	The startup could not be performed due to an error. The LSM-81 will try to restart after 12 seconds.  If the condition does not change after restarting the device, there could be a hardware problem and the device has to be sent in.
All I/O LEDs flashing steadily	Indicates a problem with the I/O board. The LSM-81 has to be sent in

## 2.4 Reset to factory default

The LSM-81 can be reset to the factory default configuration. This can be done in two ways:

### 2.4.1 Reset via Web Server

A button on the page "Service" → "Restart" can perform a Reset-to-Factory-Default:

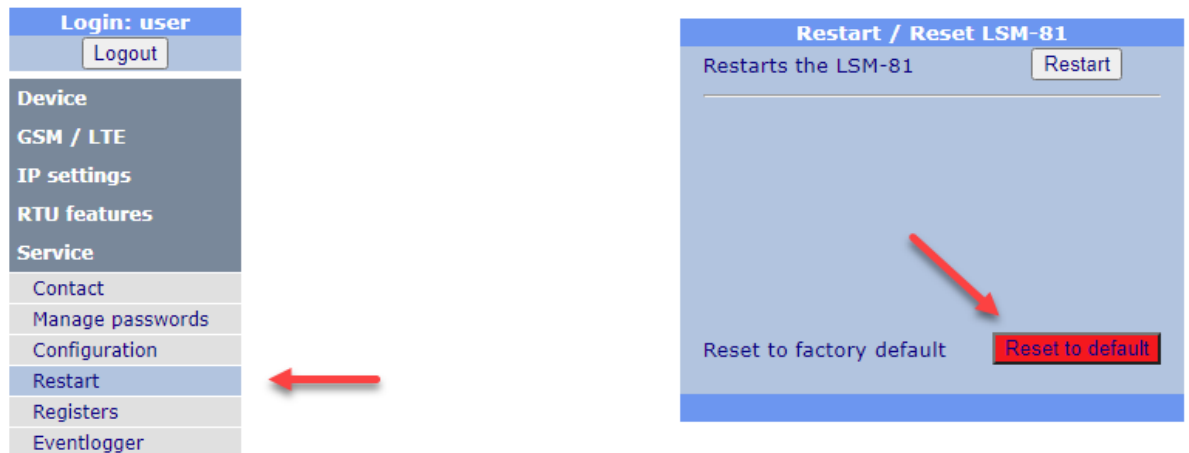

### 2.4.2 Reset via Configuration Button

- Power down the LSM-81
- Press the button behind the small hole in the back of the device with a paperclip or similar tool and keep it pressed
- Power up the device
- Keep the button pressed for at least 5 seconds until the middle 6 LED's of the RSSI bar start flashing
- The device has now started with the default configuration. The button can be released.

## 2.5 Temporary reset to default IP address

If the IP address of an LSM-81 is unknown, it can be temporarily reset to the default address:

- Press for one second on the configuration switch behind the small hole at the back of the LSM-81, until the "OK"-LED starts to flash in a 1:1 cycle
- Release the configuration button (Take care: A 5-seconds-press resets the complete device to default!)
- The LSM-81 can be now accessed on its default IP address 192.168.0.199/20. The originally configured IP can be seen and changed in the webserver on "IP settings" → "Ethernet".
- To resume to normal mode, press again for 1 second on the configuration switch, until the OK-LED resumes to be permanently on. The LSM now listens to the configured IP address

## 3 Starting up the LSM-81

---

This chapter describes how to bring the LSM-81 into service and how to register it to the GSM/LTE network.

### 3.1 Requirements

The LSM-81 has to be powered up and a GSM/LTE antenna has to be connected to the SMA connector.

**In this first steps, no SIM card should be installed.**

Furthermore, a notebook has to be connected to the device directly or via LAN. The LSM-81 has the default IP address 192.168.0.199 with the netmask 255.255.240.0.

The PC's Ethernet port has to be set to an IP address in the range of 192.168.0.1-192.168.15.254 with the same netmask or IP address 192.168.0.X with the netmask 255.255.255.0.

Supported browsers for the configuration are:

- Edge
- Chrome
- Firefox
- Safari

**Microsoft Internet Explorer is NOT supported** which can result in missing configuration parameters in the submenus.

### 3.2 Accessing the embedded web server

If the IP address of the LSM-81 (192.168.0.199) is typed into the web browser, the login page will appear:



The screenshot shows a web browser window displaying the login page for the LSM-81 configuration panel. The page has a blue header with the text "LSM-81 configuration panel" and "Funk-Electronic Piciorgros GmbH". Below the header is a login form with the title "Login (SN: 21031)". The form contains two input fields: "User" and "Password". At the bottom of the form are two buttons: "Reset" and "Login".

The first login will be done using the default username and password (take care, as both are case sensitive):

Username: "user"

Password: "user"

These passwords can be changed any time using the menu "Service" → "Manage Passwords".

After a successful login, the configuration menu of the TMO will be displayed. A navigation menu on the left side of the page allows access to the different configuration pages.

A separate footer displays the most important device parameters like Ethernet address, network operator of the GSM/LTE network as well as field strength.

Please note that the menu and footer line are only loaded once after login to reduce traffic load. The footer line has a "Refresh" link to update the information of the footer on demand.

## LSM-81 configuration panel

Funk-Electronic Piciorgros GmbH

<b>Login: user</b>
<input type="button" value="Logout"/>
<b>Device</b>
Common
COM interface
IP application interface
Access
Internal clock
<b>GSM / LTE</b>
IP settings
RTU features
Service

<b>Contact information</b>	
Company	Funk-Electronic Piciorgros GmbH
Address	Claudiastraße 5 51149 Cologne Germany
Phone	+49 2203 911 770
Fax	+49 2203 913 006
Internet	<a href="http://www.piciorgros.com">http://www.piciorgros.com</a>
E-Mail	<a href="mailto:info@piciorgros.com">info@piciorgros.com</a>

SN: 21031 | ETH-IP: 192.168.4.20 | Network: o2-de | RSSI: -73 dBm

[Refresh footer information](#)

After 5 minutes without activity the user will be automatically logged out.

### 3.2.1 Navigation using the Menu

To select a menu, move the cursor over the desired headword and click it. Then the menu will open displaying the next options

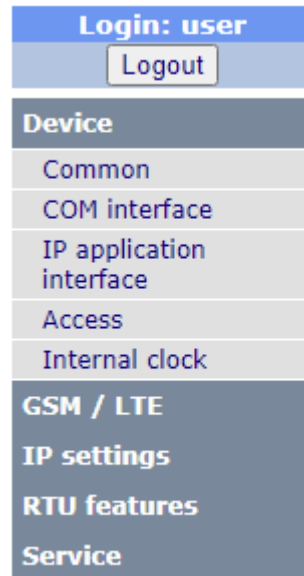

### 3.2.2 Applying changes

On the bottom of each page, on which the user can enter data or make other changes like selections via radio buttons etc. two buttons can be seen:



Each value which is entered or changed will not immediately be applied by the LSM-81. Once the settings of the page are done, the button "Apply" must be clicked – the LSM-81 will then immediately apply the new values.

If any wrong entry has been made on the page, a click on "Reset" will restore the original values, which have been transmitted initially. Note that a "Reset" will not work after the changes have been applied.

**Note:** Instead of clicking "Apply" pressing the "Enter" key will have the same function on most pages. **Pay special attention on pages where other buttons are used:** In this case the first button on the page will be activated! On pages with buttons it is recommended to use the "Apply" button at the end to prevent unwanted actions!

### 3.2.3 Requesting Restart of the Device

Some configuration changes need a device restart before they will take effect.

If the user has made any of these changes, an orange banner with a button “Restart Device” is displayed.

It is not necessary to press this button immediately as long as other parameters need to be changed.

### 3.2.4 Session timeout and page reload

After 5 minutes of inactivity the configuration session will time out.

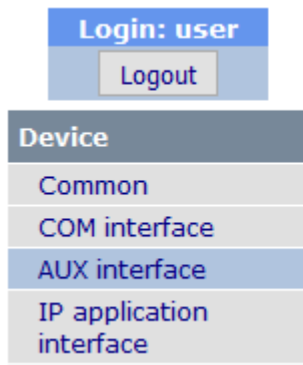

An easy way to continue the configuration session is to reload the page by hitting the F5 key.

### 3.3 Configuration of SIM PIN and own phone number

The SIM PIN of the device has to be configured before the SIM card can be inserted. By default, it is 4711. As an alternative the PIN number can also be changed to 4711 using a cell phone beforehand.

If the PIN request of the SIM card is deactivated, the device will detect this and the PIN number setup in the device will be ignored.

It is recommended to secure the SIM with a PIN number to avoid misuse in case of theft.

To set the automatic time in the device via the ATS function, the own phone number has to be entered.

In the Webserver you find this menu under "GSM/LTE" → "Configuration":

**LSM-81 configuration panel**  
Funk-Electronic Piciorgros GmbH - LSM-81 Stoermelder

Login: partner  
Logout

Device  
GSM / LTE  
Configuration  
Phonebook  
Alarm configuration  
Binary alarms  
Analog alarms  
Status  
IP settings  
RTU features  
PicoLogo  
Service

**GSM/LTE Configuration**

Own telephone number + 4917212345678  
SIM PIN 4711 [4 digit]

**LTE IP communication**

APN internet  
Activate LTE-IP  Off  On  
Internet connection monitor timeout (min) 5 [1 - 60]  
Re-Register to LTE at expiry  Off  On  
Send notification at expiry  Off  On

**MDP-810 connection**

MDP radio layer address 1 [1 - 65500]  
LSM-81 slave address 1 [1 - 239]

**Attention:**

All number have to be entered in the international format without the „+“. As an example, the German cell phone number 0172/1234567 would be entered as 491721234567.

From version 1.44 the LSM-81 attempts to get its own phone number from the SIM card. In case the SIM delivers the own number, it's automatically configured and can't be edited on this page.

Editing of the number is only possible if the SIM card does not provide the own number. In this case the editing is possible around one minute after starting the LSM-81.

### 3.4 Inserting the SIM card

The SIM card reader is on the left side of the device. The SIM has to be inserted with the numbers facing up and the cut corner facing the device. The SIM card shall be inserted with the device powered off.

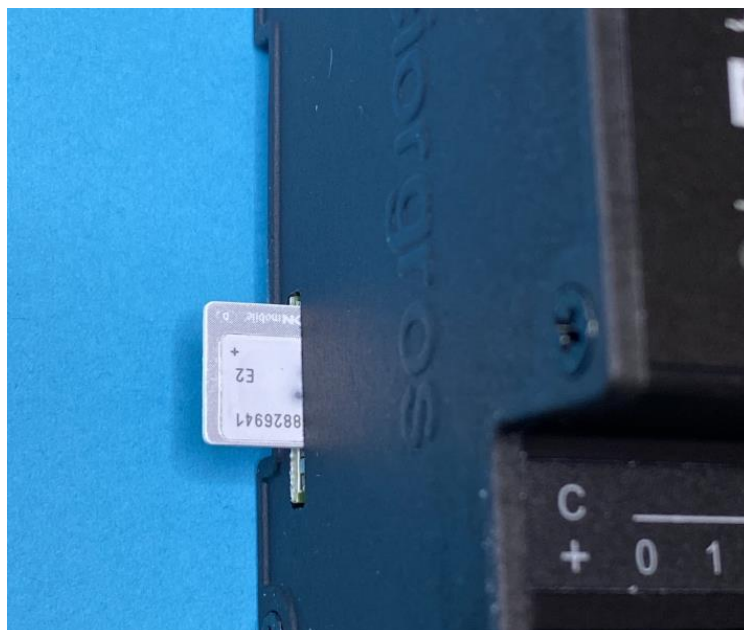

The card had to be pushed into the device until a „click” locks the card.

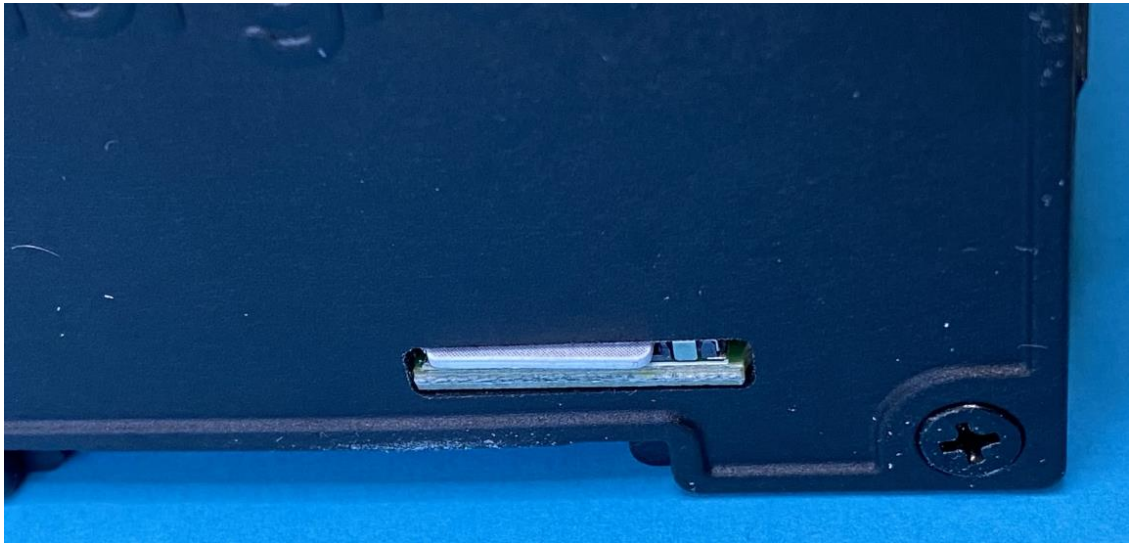

### 3.4.1 Removing the SIM card

To remove the SIM card, it has to be pushed a little into the device until a click unlocks the card reader.

The card will be ejected by the card reader and can be removed.

The device should be powered off to remove the SIM card.

### 3.5 First registration to the mobile network

The device can be registered to the mobile network, after the SIM PIN has been inserted and the own phone number has been configurated. An antenna should be connected to the device.

The device starts up after power is supplied. At first the "Pwr" and "OK" LEDs light up. Afterwards the LTE module is being initiated, while the red field strength LED shows numerous flashing codes.

After successful initialization the red LED should not flash anymore and the RSSI display should show the receiving field strength of the LTE module. In this case if the red LED is on, the field strength is not sufficient and should be improved (different external antenna, improved antenna position, antenna outside of the building etc.).

If the red LED slowly flashes in a 1:1 cycle the device is searching for a mobile network. If the flashing continues for a while, it means that there is either no network coverage or the SIM has not been activated by the cellular network operator.

Fast flashing of the red LED (1:1 cycle) indicates a SIM card error. The SIM is either unreadable, not inserted correctly or the PIN entered in the device does not match the SIM PIN.

**In this case the configured SIM PIN in the device should be validated! If the device is started with a wrong PIN number three consecutive times, the SIM will be locked and has to be unlocked by inserting the SIM into a mobile phone and entering the SIM PUK!**



**LSM-81, registered to a mobile network  
with perfect field strength**

### 3.5.1 Requesting the cellular radio status in the Webserver

More information on the LTE module and the cellular network can be found in the menu "GSM/LTE" → "Status".

Besides the software version of the LTE Module, the IMSI and IMEI numbers and the current network information can be viewed in this submenu.

## LSM-81 configuration panel

Funk-Electronic Piciorgros GmbH - LSM-81 Stoermelder

<div style="background-color: #4a7ebb; color: white; padding: 2px;">Login: partner</div> <div style="text-align: right; padding: 2px;"><a href="#" style="color: white;">Logout</a></div> <div style="background-color: #4a7ebb; color: white; padding: 2px; margin-top: 5px;">Device</div> <div style="background-color: #4a7ebb; color: white; padding: 2px; margin-top: 2px;">GSM / LTE</div> <div style="background-color: #4a7ebb; color: white; padding: 2px; margin-top: 2px;">Configuration</div> <div style="background-color: #4a7ebb; color: white; padding: 2px; margin-top: 2px;">Phonebook</div> <div style="background-color: #4a7ebb; color: white; padding: 2px; margin-top: 2px;">Alarm configuration</div> <div style="background-color: #4a7ebb; color: white; padding: 2px; margin-top: 2px;">Binary alarms</div> <div style="background-color: #4a7ebb; color: white; padding: 2px; margin-top: 2px;">Analog alarms</div> <div style="background-color: #4a7ebb; color: white; padding: 2px; margin-top: 2px; border-bottom: 2px solid #4a7ebb;">Status</div> <div style="background-color: #4a7ebb; color: white; padding: 2px; margin-top: 2px;">IP settings</div> <div style="background-color: #4a7ebb; color: white; padding: 2px; margin-top: 2px;">RTU features</div> <div style="background-color: #4a7ebb; color: white; padding: 2px; margin-top: 2px;">PicoLogo</div> <div style="background-color: #4a7ebb; color: white; padding: 2px; margin-top: 2px;">Service</div>	<div style="background-color: #4a7ebb; color: white; padding: 2px; margin-bottom: 5px;">Device information</div> <table style="width: 100%; border-collapse: collapse;"> <tr> <td style="padding: 2px;">LTE engine version:</td> <td style="text-align: right; padding: 2px;">20.00.416</td> </tr> <tr> <td style="padding: 2px;">IMSI:</td> <td style="text-align: right; padding: 2px;">[REDACTED]</td> </tr> <tr> <td style="padding: 2px;">IMEI:</td> <td style="text-align: right; padding: 2px;">356530112809849</td> </tr> <tr> <td style="padding: 2px;">Registration status</td> <td style="text-align: right; padding: 2px;">Registered, home network</td> </tr> <tr> <td style="padding: 2px;">Cell name</td> <td style="text-align: right; padding: 2px;">Simply</td> </tr> <tr> <td style="padding: 2px;">Cell channel</td> <td style="text-align: right; padding: 2px;">3350</td> </tr> <tr> <td style="padding: 2px;">Cell ID</td> <td style="text-align: right; padding: 2px;">454</td> </tr> <tr> <td style="padding: 2px;">Cell TAC</td> <td style="text-align: right; padding: 2px;">8D42</td> </tr> <tr> <td style="padding: 2px;">Cell net code</td> <td style="text-align: right; padding: 2px;">26203</td> </tr> </table> <div style="background-color: #4a7ebb; color: white; padding: 2px; margin-bottom: 5px;">Network information</div> <table style="width: 100%; border-collapse: collapse;"> <tr> <td style="padding: 2px;">Current network:</td> <td style="text-align: right; padding: 2px;">Simply</td> </tr> <tr> <td style="padding: 2px;">Field strength</td> <td style="text-align: right; padding: 2px;">-69 dBm</td> </tr> <tr> <td style="padding: 2px;">LTE modem IP</td> <td style="text-align: right; padding: 2px;">---</td> </tr> </table>	LTE engine version:	20.00.416	IMSI:	[REDACTED]	IMEI:	356530112809849	Registration status	Registered, home network	Cell name	Simply	Cell channel	3350	Cell ID	454	Cell TAC	8D42	Cell net code	26203	Current network:	Simply	Field strength	-69 dBm	LTE modem IP	---
LTE engine version:	20.00.416																								
IMSI:	[REDACTED]																								
IMEI:	356530112809849																								
Registration status	Registered, home network																								
Cell name	Simply																								
Cell channel	3350																								
Cell ID	454																								
Cell TAC	8D42																								
Cell net code	26203																								
Current network:	Simply																								
Field strength	-69 dBm																								
LTE modem IP	---																								

Part of this information can also be found in the footer of the webserver. If necessary the footer has to be updated by clicking on "Refresh Footer Information".

SN: 21031 | ETH-IP: 192.168.4.20 | Network: Simply | RSSI: -73 dBm

[Refresh footer information](#)

### 3.6 Basic configuration of the device

The basic configuration of the device's basic and signaling features can be found under menu "GSM/LTE" → "Configuration"

## LSM-81 configuration panel

Funk-Electronic Piciorgros GmbH - LSM-81 Stoermelder

Login: partner  
[Logout](#)

Device

GSM / LTE

Configuration ←

Phonebook

Alarm configuration

Binary alarms

Analog alarms

Status

IP settings

RTU features

PicoLogo

Service

#### GSM/LTE Configuration

Own telephone number +

SIM PIN  [4 digit]

#### LTE IP communication

APN

Activate LTE-IP  Off  On

Internet connection monitor timeout (min)  [1 - 60]

Re-Register to LTE at expiry  Off  On

Send notification at expiry  Off  On

#### MDP-810 connection

MDP radio layer address  [1 - 65500]

LSM-81 slave address  [1 - 239]

Primary MDP FQDN/IP

Primary MDP Port  [1 - 65500]

Secondary MDP FQDN/IP

Secondary MDP Port  [1 - 65500]

M2M SIM (Private VPN)  Off  On

MDP connection monitor timeout (min)  [1 - 60]

Send notification at expiry  Off  On

#### Notifications

Notification target  ▼

OK-Message on these weekdays  Mon  Tue  Wed  Thu  Fri  Sat  Sun

OK-Message at this time  :

Send restart message  Off  On

Send CP warnings  Off  On

#### Time synchronisation

When operating as a slave to a MDP-810, the time will be synchronized from the MDP-810. You can leave these options to "off" in this case.

ATS  Off  On

ATS (own) number +4917212345678

SNTP  Off  On

#### MMI

MMI enable  Off  On

Limit to phonebook  Off  On

Access PIN  [4 digit]

Configuration point	Description
GSM/LTE-Configuration	
Own telephone number	The individual phone number of the inserted SIM should be added here. This is essential to receive the time daily via the GSM/LTE network (ATS-Function).
SIM-PIN	The PIN number of the inserted SIM card.
LTE-IP-Configuration	
Go to chapter 5.2 "Setting the LSM-81 up for a connection to the internet"	
Verbindung zu MDP-810 Connetion to the MDP-810	
Go to Chapter 5.3 "Setting up the connection to an MDP-810"	
Benachrichtigungen Notifications	
Notification target	The recipient of system notifications of the LSM-81
OK-message on these weekdays	Selection of weekdays on which an "OK" message should be sent. The OK Message contains the device name, the current field strength and the status of the cost protection.
OK-Message at this time	Time at which OK message should be sent out
Send restart message	Sends out an additional SMS to a configured number when the device has restarted (after power failure for example)
Send CP warnings	Send one warning for each of the both scenarios: Cost protection has reached 10 and cost protection has reached 0.
Time synchronization	
ATS	Activates the daily synchronization of the time via the ATS function. The device will send an SMS to itself containing the local time from the cellular network
ATS (own) number	Shows the devices own number entered under "GSM/LTE" → "Configuration"
SNTP	Activates the setup of the time via SNPT in case the device is located where there is either a local NTP server or one reachable via the internet using the Ethernet port.  The NPT server and the time zone can be setup under "Device" → "Internal clock"
MMI	
MMI enable	Activates the control feature via MMI commands
Limit to phonebook	When activated MMI commands can only be executed when sent from a device that is listed in the phone book of the LSM-81 for more security.
Access PIN	The MMI commands contain a PIN number. Only commands containing the correct access PIN will be executed by the LSM-81  Default: 4711

## 4 Alarm Module Functions

---

### 4.1 Description of Functions

A crucial function of the Alarm module is alarm blocks. The LSM-81 offers 24 digital Alarm blocks and 16 analog alarm blocks.

An individual alarm text as well as individual alarm features can be setup for each alarm block. The allocation of the alarm block to the digital or analog inputs is freely selectable so that different analog values will trigger different alarm messages as multiple alarm block are referring to the same analog input.

#### 4.1.1 Alarming Procedure

Once the configured trigger criteria is met (in the most simple case the activation of a digital input), the turn-on delay will elapse. This delay can be set to 0-60 seconds. This means that the trigger criteria has to be fulfilled for given amount of time before the alarm is released.

Furthermore, the user has the choice to setup the alarms to only be sent in a certain time frame or any time.

An alarm can be configured to be sent with or without an acknowledgement. If an alarm SMS is sent without acknowledgement, it will contain the alarm text and optionally the device name and time stamp and it will be sent to the configured recipient(s). Afterwards a potential re-alarming time has to elapse before the alarm cycle is terminated.

There are two ways to send an alarm with acknowledgement: parallel or sequential alarm transmission. Parallel means that all alarm recipients will receive the alarm at the same time. Afterwards the acknowledgement time will run out. While the acknowledgement time is running out, a recipient can acknowledge the receipt of the alarm by sending any SMS to the LSM-81 or giving it a voice call. If this occurs, the acknowledgement waiting time runs out and the alarm cycle terminates. If the receipt is not acknowledged a preconfigured supervisor will receive a message with the information that the alarm has not been acknowledged and the alarm cycle terminates afterwards.

The sequential alarm cycle is similar with the difference that the recipients will receive the alarm message one after the other. In this case the LSM-81 will send the alarm message to the first recipient and wait for the acknowledgement time to run out. If no acknowledgement is sent back to the device after the time ran out, the LSM will send the alarm message to the next recipient. This procedure will be repeated until the LSM-81 has sent the message to all recipients. If no acknowledgement has been sent back to the device after all recipients have received the alarm, the LSM-81 will send the alarm message to a supervisor and the alarm cycle terminates. An acknowledgement during the procedure from one recipient will terminate the cycle immediately and other recipients will not receive the alarm message.

A triggered alarm can optionally perform an output action: a freely selectable binary output can be turned on, off or turned on for 1-15 seconds as an impulse after an alarm block is triggered.

#### 4.1.2 Acknowledging an alarm

If an alarm has to be acknowledged, the LSM will indicate this in the alarm text with the words "[PLS ACKNOWLEDGE]":

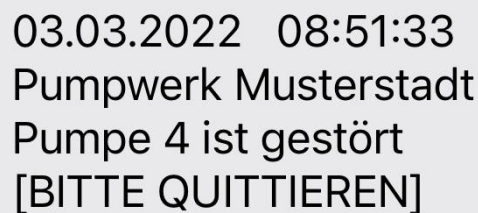
A screenshot of an SMS message in a grey speech bubble. The text is: "03.03.2022 08:51:33 Pumpwerk Musterstadt Pumpe 4 ist gestört [BITTE QUITTIEREN]".

03.03.2022 08:51:33  
Pumpwerk Musterstadt  
Pumpe 4 ist gestört  
[BITTE QUITTIEREN]

The recipient of the alarm has the following options:

- They send any SMS as a reply to the number of the LSM-81. If the LSM receives an SMS from a previously alarmed number, the alarm counts as acknowledged
- They give the phone number of the LSM a voice call. When a call is used to acknowledge an alarm, the LSM-81 will reject the call after the second dial tone (the caller will hear the busy tone). If the LSM does not reject the call and it continues to ring, there is no alarm to be acknowledged anymore (e.g. another recipient has already acknowledged the alarm.)

#### Note:

To acknowledge the alarm via voice call, the SIM card has to have the voice functionality and cannot be a pure data SIM.

We also highly recommend to turn off voice mail as well as SMS when a voice call has been missed.

An acknowledgement will be stored in the event logger of the LSM-81.

### 4.1.3 “Acknowledgement notification”

When Acknowledgement notification is turned on for an alarm block, all previously alarmed recipients will be informed about the acknowledgement via SMS.

This SMS contains the alarm text including time stamp as well as the phrase:

**[ACKNOWLEDGED by +4912345678]**

### 4.1.4 Triggering an Alarm via PicoLogo

Via the selection field "PicoLogo trigger VI", each single alarm block can be activated via PicoLogo. In PicoLogo 32 Virtual inputs (Block VIO) are available, whose status can be set in PicoLogo.

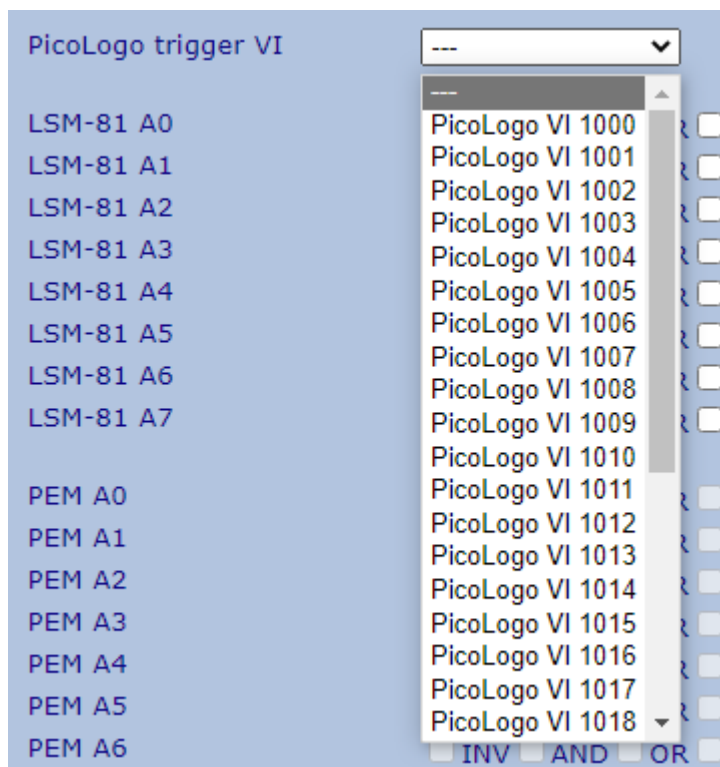

If such VI alarm block is activated, the trigger criteria are met once the VI in PicoLogo is “active”.

The switching-on delay of the alarm block is considered here as well, meaning the VI has to be active at least for the duration of the switching-on delay.

The chosen VI can be interlinked with additionally configured physical inputs of the LSM-81.

## 4.2 Alarm Configurations

# LSM-81 configuration panel

Funk-Electronic Piciorgros GmbH - LSM-81 Stoermelder

**Login: partner**  
Logout

**Device**  
GSM / LTE

Configuration  
Phonebook  
**Alarm configuration**  
Binary alarms  
Analog alarms  
Status

**IP settings**  
RTU features  
PicoLogo  
Service

Alarm configuration

Device name

Cost Protection  Off  On

Max. alarms per day  [10 - 999]

Currently remaining 25

Reset remaining alarms

---

Alarm time window

Start time  :

End time  :

Configuration points	Description
Alarm Configuration	
Device Name	The device name can be chosen here. This name will be shown in the header of the web server and can be added to alarm SMS for easier identification of the outstation, which sends the alarm.
Cost protection	Activates cost protection which limits the amount of alarms per day (priority "Normal").
Max. alarms per day	Sets the maximum amount of alarms per day sent via SMS. The counter resets to zero at midnight of each day.
Currently Remaining	The amount of currently remaining alarms for this day
Reset remaining alarms	The amount of remaining alarms can be reset to the maximum amount by clicking the „reset“ button
Alarm time window	
Start Time	Shows the start time of the time window, to which alarms can be limited. The start time can be after the end time resulting in a time window overnight.
End Time	Shows the end of the time window

### 4.3 Phone book

**LSM-81 configuration panel**  
 Funk-Electronic Piciorgros GmbH - Pumpwerk Musterstadt

Login: user

---

**Device**

**GSM / LTE**

Configuration

Phonebook

Alarm configuration

Binary alarms

Analog alarms

Status

---

**IP settings**

RTU features

Service

Index	Number (+xxxxx)	Name
Supervisor	+ <input type="text" value="4917308150815"/>	<input type="text" value="Dagobert Duck"/>
1	+ <input type="text" value="491719876543"/>	<input type="text" value="Donald Duck"/>
2	+ <input type="text" value="4917047114711"/>	<input type="text" value="Minnie Maus"/>
3	+ <input type="text" value="49172321608"/>	<input type="text" value="Oma Eusebia"/>
4	+ <input type="text" value="0"/>	<input type="text"/>
5	+ <input type="text" value="0"/>	<input type="text"/>
6	+ <input type="text" value="0"/>	<input type="text"/>
7	+ <input type="text" value="0"/>	<input type="text"/>
8	+ <input type="text" value="0"/>	<input type="text"/>
9	+ <input type="text" value="0"/>	<input type="text"/>
10	+ <input type="text" value="0"/>	<input type="text"/>
11	+ <input type="text" value="0"/>	<input type="text"/>
12	+ <input type="text" value="0"/>	<input type="text"/>
13	+ <input type="text" value="0"/>	<input type="text"/>
14	+ <input type="text" value="0"/>	<input type="text"/>
15	+ <input type="text" value="0"/>	<input type="text"/>
16	+ <input type="text" value="0"/>	<input type="text"/>
17	+ <input type="text" value="0"/>	<input type="text"/>
18	+ <input type="text" value="0"/>	<input type="text"/>
19	+ <input type="text" value="0"/>	<input type="text"/>
20	+ <input type="text" value="0"/>	<input type="text"/>
21	+ <input type="text" value="0"/>	<input type="text"/>
22	+ <input type="text" value="0"/>	<input type="text"/>
23	+ <input type="text" value="0"/>	<input type="text"/>
24	+ <input type="text" value="0"/>	<input type="text"/>
25	+ <input type="text" value="0"/>	<input type="text"/>

The phone book provides space for 25 phone numbers including names as well as a supervisor number. All numbers have to be added in international format without the "+", meaning the German phone number "017212345678" would have to be added as "4917212345678".

Each alarm block can alarm multiple consecutive entries from the phone book (from ... to). This means that theoretically an alarm block with 25 participants is possible but also 5 groups with 5 participants each can be assigned to the alarm blocks. If an alarm sees an empty entry (0), it will just ignore it and go to the next entry.

The number of the supervisor has a special function: The participant added in this field will receive a message when an acknowledgeable message has not been acknowledged.

The same phone number can be added to the phone book numerous times for example as alarm recipient but also as supervisor or as participant in multiply groups. This is how repetitions are possible (e.g. an acknowledgeable alarm will be sent to the same number multiple times).

### 4.4 Configuration of digital alarm blocks

## LSM-81 configuration panel

Funk-Electronic Piciorgros GmbH - LSM-81 Stoermelder

Login: user  
[Logout](#)

Device

GSM / LTE

Configuration

Phonebook

Alarm configuration

Binary alarms ←

Analog alarms

Status

IP settings

RTU features

PicoLogo

Service

Binary alarms

Select alarm block 1 Alarmblock 1 ▼

Alarm #1 configuration

Alarm text Alarmblock 1

On-delay (s)  [0 - 60]

Re-alarm delay (min)  [0 - 60]

Alarm type  Normal  Priority

Acknowledgement  Off  On

Alarm timing  Sequential  Parallel

ACK wait time (s)  [15 - 120]

Acknowledge notification  Off  On

Alarm activation  Always  Time window

Add time stamp  Off  On

Add device name  Off  On

First alarm recipient 1 | +491719876543 | Donald Duck ▼

Last alarm recipient 3 | +49172321608 | Oma Eusebia ▼

Alarm #1 output action

Output selection --- ▼

Output action  Pulse  Activate  Deactivate

Pulse duration (s)  [1 - 15]

Alarm #1 activation matrix

PicoLogo trigger VI --- ▼

LSM-81 A0	<input type="checkbox"/> INV <input checked="" type="checkbox"/> AND <input type="checkbox"/> OR <input type="checkbox"/> XOR
LSM-81 A1	<input type="checkbox"/> INV <input type="checkbox"/> AND <input type="checkbox"/> OR <input type="checkbox"/> XOR
LSM-81 A2	<input type="checkbox"/> INV <input type="checkbox"/> AND <input type="checkbox"/> OR <input type="checkbox"/> XOR
LSM-81 A3	<input type="checkbox"/> INV <input type="checkbox"/> AND <input type="checkbox"/> OR <input type="checkbox"/> XOR
LSM-81 A4	<input type="checkbox"/> INV <input type="checkbox"/> AND <input type="checkbox"/> OR <input type="checkbox"/> XOR
LSM-81 A5	<input type="checkbox"/> INV <input type="checkbox"/> AND <input type="checkbox"/> OR <input type="checkbox"/> XOR
LSM-81 A6	<input type="checkbox"/> INV <input type="checkbox"/> AND <input type="checkbox"/> OR <input type="checkbox"/> XOR
LSM-81 A7	<input type="checkbox"/> INV <input type="checkbox"/> AND <input type="checkbox"/> OR <input type="checkbox"/> XOR
PEM A0	<input type="checkbox"/> INV <input type="checkbox"/> AND <input type="checkbox"/> OR <input type="checkbox"/> XOR
PEM A1	<input type="checkbox"/> INV <input type="checkbox"/> AND <input type="checkbox"/> OR <input type="checkbox"/> XOR
PEM A2	<input type="checkbox"/> INV <input type="checkbox"/> AND <input type="checkbox"/> OR <input type="checkbox"/> XOR
PEM A3	<input type="checkbox"/> INV <input type="checkbox"/> AND <input type="checkbox"/> OR <input type="checkbox"/> XOR
PEM A4	<input type="checkbox"/> INV <input type="checkbox"/> AND <input type="checkbox"/> OR <input type="checkbox"/> XOR
PEM A5	<input type="checkbox"/> INV <input type="checkbox"/> AND <input type="checkbox"/> OR <input type="checkbox"/> XOR
PEM A6	<input type="checkbox"/> INV <input type="checkbox"/> AND <input type="checkbox"/> OR <input type="checkbox"/> XOR
PEM A7	<input type="checkbox"/> INV <input type="checkbox"/> AND <input type="checkbox"/> OR <input type="checkbox"/> XOR
PEM B0	<input type="checkbox"/> INV <input type="checkbox"/> AND <input type="checkbox"/> OR <input type="checkbox"/> XOR
PEM B1	<input type="checkbox"/> INV <input type="checkbox"/> AND <input type="checkbox"/> OR <input type="checkbox"/> XOR
PEM B2	<input type="checkbox"/> INV <input type="checkbox"/> AND <input type="checkbox"/> OR <input type="checkbox"/> XOR
PEM B3	<input type="checkbox"/> INV <input type="checkbox"/> AND <input type="checkbox"/> OR <input type="checkbox"/> XOR
PEM B4	<input type="checkbox"/> INV <input type="checkbox"/> AND <input type="checkbox"/> OR <input type="checkbox"/> XOR
PEM B5	<input type="checkbox"/> INV <input type="checkbox"/> AND <input type="checkbox"/> OR <input type="checkbox"/> XOR
PEM B6	<input type="checkbox"/> INV <input type="checkbox"/> AND <input type="checkbox"/> OR <input type="checkbox"/> XOR
PEM B7	<input type="checkbox"/> INV <input type="checkbox"/> AND <input type="checkbox"/> OR <input type="checkbox"/> XOR

[Reset](#) [Apply](#)

Configuration Point	Description
Binary alarms	
Select alarm block	The alarm block which should be configured can be chosen with this dropdown field.
Alarm #x configuration	
Alarm text	The message text sent in alarm messages. It can be up to 60 characters long.
On-delay (s)	Indicates the turn-on delay in seconds.  To trigger the alarm, the trigger criteria have to be fulfilled for that number of seconds.
Re-alarm delay (min)	Indicates the re-alarmsing time in minutes.  If the alarming of a block is terminated and a time has been configured here, this alarm block cannot be triggered again before the re-alarmsing time has expired.
Alarm type	<ul style="list-style-type: none"> <li>• Normal: Alarm is sent out with normal priority; the value of the cost protection is reduced by 1 with each transmission. If the cost protection ran down to 0, no more alarms will be sent.</li> <li>• Priority: Alarms are sent out with priority. If more than one alarm needs to be sent out via SMS, the prioritized ones will be sent first. Alarms with priority will not reduce the cost protection and can even be sent out if the cost protection counter is at 0.</li> </ul>
Acknowledgement	Indicates whether a message needs to be acknowledged.
Alarm timing	<ul style="list-style-type: none"> <li>• Sequential: The alarm participants will be notified one after the other. After each transmission that acknowledgement wait time needs to elapse.</li> <li>• Parallel: All alarm participants are notified at the same time. Afterwards the acknowledgement wait time elapses just once for all participants.</li> </ul>
ACK wait time (s)	The acknowledgement time in seconds
Acknowledge notification	The previous alarm participants receive an SMS after an alarm has been acknowledged
Alarm activation	<ul style="list-style-type: none"> <li>• Always: The alarm block can be triggered at any time</li> <li>• Time window: The alarm block can only be sent in a pre-configured time frame.</li> </ul>
Add time stamp	If activated a time stamp will be added to the alarm messages
Add device name	If activated the device name is added to the alarm message, from which the text was sent.
First alarm recipient Last alarm recipient	Determines the alarm participants. The alarm is sent to the participant "First alarm recipient" first, and then sends it out to the following participants until "Last alarm recipient" is reached.  When parallel alarms or non-acknowledgeable alarms are sent out, all members of the phone book receive the message at the same time from "First alarm recipient" to "Last alarm recipient".

Configuration Point	Description
Alarm #x output action	
Output selection	Determines the binary output, which will perform an action once a message block is triggered.
Output action	Determines the action the output should perform: <ul style="list-style-type: none"> <li>• Pulse: If an alarm is triggered the output will be activated for a preconfigured time.</li> <li>• Activate: If an alarm block is triggered the output is activated</li> <li>• Deactivate: If an alarm block is triggered the output is deactivated</li> </ul>
Pulse duration (s)	Only visible if "Pulse" is active Determines the duration of the pulse
Switch back	Only visible if "Activate" / "Deactivate" is active Deactivates the output after the trigger criteria are terminated, meaning when "Activate" is selected the output will be turned off, when "deactivate" is selected it will be turned on.
Alarm #x activation matrix	
PicoLogo trigger VI	A virtual PicoLogo input can be chosen, which will trigger the alarm block
<p>The 24 useable binary inputs are listed here. Each input has four check boxes:</p> <ul style="list-style-type: none"> <li>• INV: Inverts the input for the alarm block, meaning an inverted binary input that is deactivated will be active for the alarm block and vice versa.</li> <li>• AND: All binary inputs that have the box "AND" checked have to active to fulfill the trigger criteria. If only one binary input has the box "AND" checked, the activation of the input will fulfill the trigger criteria.</li> <li>• OR: If at least one of the binary inputs that have the box "OR" checked is active, the trigger criteria are met.</li> <li>• XOR: If exactly one of the binary inputs that have the box "XOR" checked is active, the trigger criteria are met.</li> </ul> <p>The results of the columns "AND", "OR" und "XOR" OR-linked meaning: If input "A0" and "A1" have box "AND" checked and additionally input "A2" has box "OR" checked the trigger criteria is met when either both inputs "A0" and "A1" or output "A2" are active</p> <p><b>Notice:</b></p> <p>The 16 binary inputs "PEM A0" until "PEM B0" are only active when an expansions module (PEM-16DIO, PEM-16DI or PEM-32DI) is connected to the LSM. Otherwise the fields are greyed out and cannot be selected.</p> <p>If there are more than 24 binary inputs available (when using expansions modules), only the first 24 inputs can be used for alarm block configurations. Additional inputs can be addressed via the PicoLogo or RTU function in combination with an MDP-810).</p>	

### 4.5 Configuration of analog Alarm blocks

## LSM-81 configuration panel

Funk-Electronic Piciorgros GmbH - LSM-81 Stoermelder

Login: user

Logout

---

Device

GSM / LTE

Configuration

Phonebook

Alarm configuration

Binary alarms

Analog alarms ←

Status

---

IP settings

RTU features

PicoLogo

Service

### Analog alarms

Select alarm block 1 Abwassertank hat Leerungsgrenze erreicht ▼

---

#### Alarm #1 configuration

Alarm text Abwassertank hat Leerungsgrenze erreicht

On-delay (s) 60 [0 - 60]

Re-alarm delay (min) 0 [0 - 60]

Alarm type  Normal  Priority

Acknowledgement  Off  On

Alarm activation  Always  Time window

Add time stamp  Off  On

Add device name  Off  On

First alarm recipient 1 | +491719876543 | Donald Duck ▼

Last alarm recipient 3 | +49172321608 | Oma Eusebia ▼

---

#### Alarm #1 output action

Output selection PEM C0 ▼

Output action  Pulse  Activate  Deactivate

Switch back  Off  On

---

#### Alarm #1 activation parameters

PicoLogo trigger VI --- ▼

Trigger input LSM-81 D0 ▼

Scaling low 0,000 [-9999.000 - 9999.000]

Scaling high 20,500 [-9999.000 - 9999.000]

Hysteresis 0,500 [0.000 - 999.000]

Unit m3

Trigger value 15,000 [-9999.000 - 9999.000]

Sensor type  0-20mA  4-20mA

Activation criteria Exceedance ▼

Scaling check OK

Reset
Apply

Konfigurationspunkt	Beschreibung
Binary alarms	
Select alarm block	The alarm block which should be configured can be chosen with this dropdown field.
Alarm #x configuration	
Alarm text	Shows the message text, which will be sent in alarm messages. It can be up to 60 characters long.
On-delay (s)	Indicates the turn-on delay in seconds.  If a time is entered here, this is the time the trigger criteria have to be fulfilled uninterruptedly to trigger the alarm block.
Re-alarm delay (min)	The re-arming time in minutes.  If an alarming of a block terminates and a time is entered in this field, no other alarm can be triggered before the re-arming time elapses.
Alarm type	<ul style="list-style-type: none"> <li>• Normal: Alarm is sent out with normal priority; the value of the cost protection is reduced by 1 with each transmission. If the cost protection ran down to 0, no more alarms will be sent.</li> <li>• Priority: Alarms are sent out with priority. If more than one alarm needs to be sent out via SMS, the prioritized ones will be sent first. Alarms with priority will not reduce the cost protection and can even be sent out when the cost protection counter is at 0.</li> </ul>
Acknowledgement	Indicates whether a message needs to be acknowledged.
Alarm timing	<ul style="list-style-type: none"> <li>• Sequential: The alarm participants will be notified one after the other. After each transmission that acknowledgement time needs to elapse.</li> <li>• Parallel: All alarm participants are notified at the same time. Afterwards the acknowledgement time elapses just once for all participants.</li> </ul>
ACK wait time (s)	The acknowledgement time in seconds
Acknowledge notification	The previous alarm participants receive an SMS after an alarm has been acknowledged
Alarm activation	<ul style="list-style-type: none"> <li>• Always: The alarm block can be triggered at any time</li> <li>• Time window: The alarm block can only be sent in a pre-configured time frame.</li> </ul>
Add time stamp	If activated a time stamp will be added to the alarm messages
Add device name	If activated the device is added to the alarm message, from which the text was sent.
First alarm recipient Last alarm recipient	Determines the alarm participants. The alarm is sent to the participant "First alarm recipient" first, and then sends it out the following participants until "Last alarm recipient" is reached.  When parallel alarms or non-acknowledgeable alarms are sent out, all members of the phone book receive the message at the same time from "First alarm recipient" to "Last alarm recipient".

Configuration Point	Description
Alarm #x output action	
Output selection	Determines the binary output, which will perform an action once a message block is triggered.
Output action	Determines the action the output should perform: <ul style="list-style-type: none"><li>• Pulse: When an alarm is triggered the output will be activated for a preconfigured time.</li><li>• Activate: When an alarm block is triggered the output is activated</li><li>• Deactivate: When an alarm block is triggered the output is deactivated</li></ul>
Pulse duration (s)	Only visible when "Pulse" is active Determines the duration of the pulse
Switch back	Only visible when "Activate" / "Deactivate" is active Deactivates the output after the trigger criteria are terminated, meaning when "Activate" is selected the output will be turned off, when "deactivate" is selected it will be turned on.

Configuration Point	Description
Alarm #x activation parameters	
PicoLogo trigger VI	In this field a virtual input from PicoLogo can be chosen, which will trigger an alarm block
Trigger input	Input, which will be used for the alarm block.  A maximum of 10 analog inputs can be used here. Analog inputs "PEM A0" until "PEM A7" can only be selected when a PEM-08AI expansion module is connected to the LSM-81.
Scaling low Scaling high	Determines the scaling of the analog input. Values from -9999 until +9999 with three decimals can be entered.  The value "Scaling low" indicates the scaled value, which is equivalent to an analog value of 0mA respectively 4mA (when using a 4-20mA sensor).  The value "Scaling high" indicates the scaled value, which is equivalent to an analog value of 20mA.  The analog values have an internal resolution of 12 bit.
Hysteresis	The hysteresis value that needs to be reached after a trigger of an alarm to reactive the trigger criteria.  If the scalable range of the blocks lie e.g. between 0 and 10 and the trigger value at 5 with a hysteresis of 0.5, the following will happen: <ul style="list-style-type: none"> <li>• If the value of a message block (which is set to 5 for the trigger) is exceeded, the value has to drop to 4.5 after it was triggered in order to reactivate the alarm blocks for the next release.</li> <li>• If the value of a message block (which is set to 5 for the trigger) is undercut, the value has to drop to 4.5 after it was triggered in order to reactivate the alarm blocks for the next release.</li> </ul>
Unit	Text field for the unit of the scaling (e.g. m <sup>3</sup> for a water tank)  Helps when entering a value and will be added to the analog value via MMI when requested.
Trigger value	The value within a configured scaling range, which will lead to the trigger of an alarm when met/exceeded or met/undercut.  The value must be within the "Scaling low" and "Scaling high" range.
Sensor type	Indicates whether a 0-20mA or 4-20mA sensor is attached
Activation criteria	<ul style="list-style-type: none"> <li>• Exceedance: The alarm criteria are met when the configured "Trigger value" is met or exceeded</li> <li>• Undercut: The alarm criteria are met when the configured "Trigger value" is met or undercut</li> </ul>
Scaling check	Validity check for the configuration. Should display "OK".  If "ERROR" is displayed the configuration has to be checked e.g. the trigger value is not within the scaled range or the trigger value plus/minus of the hysteresis is not within the range.

## 5 Online-RTU-Function

---

Starting with firmware 1.40 the LSM-81 can operate as an LTE substation of an MDP-810.

In this case the LSM-81 uses LTE data transmission to regularly send out its analog inputs and outputs as well as its counters with the master device. Its internal inputs and outputs can be expanded with up to 16 PEM expansions modules.

### 5.1 Requirements and Functioning

#### 5.1.1 Requirements

The following requirements must be met for the operation with an MDP-810 master station:

- The LSM-81 must have an inserted SIM card, which has LTE enabled.
- The MDP-810 must be accessible via the internet using a fixed IP address or FQDN. The MDP-810 uses port 8110 for all incoming data from outstations.

A DynDNS provider could also be used, however, this can result in minute long connectivity drops when the public IP address of the internet connection (to which the MDP-810 is connected to) changes.

#### 5.1.2 Functioning

Each LSM-81 can be configured to maintain up to two MDP-810 connections. This is useful when the master is setup in redundancy mode with two MDP-810 and the LSM-81 shall communicate with either one.

In this case the LSM-81 keeps the connection to both MDP-810, but only the active MDP will gather data from the LSM.

The connection is always setup from the LSM-81 side to pass through the firewall of the network provider. After the connection is established, the LSM-81 sends out a short data telegram every 45 seconds (so called Heartbeat), which will keep the firewall of the network provider open. Only with an open connection through the firewall the MDP-810 can gather data from the LSM-81.

The MDP will gather data from the LSM-81 in intervals preset in the configuration of the MDP. Commands will be transmitted immediately to the LSM-81.

If preconfigured, a change in binary inputs or an alarm trigger will result in the LSM sending a request to the MDP to gather its data immediately.

In case an M2M SIM is used, the heartbeat can be prolonged to 5 minutes as the SIM can be used via a VPN of the network provider without a firewall.

### **5.1.3 Data Usage**

The daily data usage of an LSM-81 with a stable connectivity to two MDP-810 and being polled by the active MDP every 60 seconds, is roughly half a megabyte.

This adds up to less than 20MB per month.

Additional pollings will lead to a higher data usage.

## 5.2 Setting the LSM-81 up for a connection to the internet

Under "GSM/LTE" → "LTE IP-Communication" the data connection can be set up

### LSM-81 configuration panel

Funk-Electronic Piciorgros GmbH - LSM-81

<p><b>Login: user</b></p> <p style="text-align: center;"><input type="button" value="Logout"/></p> <p><b>Device</b></p> <p><b>GSM / LTE</b></p> <p>Configuration ←</p> <p>Phonebook</p> <p>Alarm configuration</p> <p>Binary alarms</p> <p>Analog alarms</p> <p>Status</p> <p><b>IP settings</b></p> <p><b>RTU features</b></p> <p>Service</p>	<div style="background-color: #4a86e8; color: white; padding: 2px; text-align: center; font-weight: bold;">GSM/LTE Configuration</div> <p>Own telephone number + <input type="text" value="4917212345678"/></p> <p>SIM PIN <input type="text" value="4711"/> [4 digit]</p> <div style="border: 2px solid red; padding: 5px; margin-top: 5px;"> <div style="background-color: #4a86e8; color: white; padding: 2px; text-align: center; font-weight: bold;">LTE IP communication</div> <p>APN <input type="text" value="internet"/></p> <p>Activate LTE-IP <input type="radio"/> Off <input checked="" type="radio"/> On</p> <p>Internet connection monitor timeout (min) <input type="text" value="1"/> [1 - 60]</p> <p>Re-Register to LTE at expiry <input type="radio"/> Off <input checked="" type="radio"/> On</p> <p>Send notification at expiry <input type="radio"/> Off <input checked="" type="radio"/> On</p> <p>Send notification when OK again <input type="radio"/> Off <input checked="" type="radio"/> On</p> </div> <div style="background-color: #4a86e8; color: white; padding: 2px; text-align: center; font-weight: bold; margin-top: 5px;">MDP-810 connection</div> <p>MDP radio layer address <input type="text" value="4713"/> [1 - 65500]</p> <p>LSM-81 slave address <input type="text" value="16"/> [1 - 239]</p> <p>Primary MDP FQDN/IP <input type="text" value="cloud.fep.de"/></p> <p>Primary MDP Port <input type="text" value="8110"/> [1 - 65500]</p> <p>Secondary MDP FQDN/IP <input type="text" value="cloud.fep.de"/></p> <p>Secondary MDP Port <input type="text" value="8111"/> [1 - 65500]</p> <p>M2M SIM (Private VPN) <input checked="" type="radio"/> Off <input type="radio"/> On</p> <p>MDP connection monitor timeout (min) <input type="text" value="1"/> [1 - 60]</p> <p>Send notification at expiry <input type="radio"/> Off <input checked="" type="radio"/> On</p> <p>Send notification when OK again <input type="radio"/> Off <input checked="" type="radio"/> On</p>
--	---

Configuration Point	Description
LTE IP-CommuniCation	
APN	Shows the APN used for the connection. It depends on the network provider and can be requested there.
Activate LTE-IP	Global switch for IP Connection. If turned „on“, the LSM-81 will establish an IP connection. If turned “off”, no connection to the MDP-810 is available.  If this switch is off, the following configuration entries are not shown.
Internet connection monitor timeout (min)	The LSM-81 constantly checks the internet connection. If the connection is not available for the time stated here, one of the following actions will take place. More details below.  Default Value: 5 minutes
Re-Register to LTE at expiry	If the value stated above is exceeded, the LTE modem will be restarted to enforce a new registration into the LTE network.
Send notification at expiry	If turned „on“, an SMS notification will be sent to the preset number (see below) after the expiration of the timer.
Send notification when OK again	If turned „on“, an SMS will be sent out as soon as the Internet connection is reestablished.  This menu point will only be visible when “Send notification at expiry” is turned on as well.

### 5.2.1 Internet connection monitor

The connection monitor is enforced if at least one MDP-810 connections is preconfigured. It contains one timeout with a value of 1 to 60 minutes. By default, this time is set to 5 minutes.

Each data packet received via LTE sets this timer back.

If the LSM-81 does not receive a data packet from the MDP-810 or respond to heartbeat data packets and the time runs out, the monitor will do a check on the internet connection.

The LSM-81 will now send a ping to 8.8.8.8 (Google DNS service). If this ping fails, another ping will be sent to IP 1.1.1.1 (Cloudflare DNS). Both services are considered highly available.

This additional test avoids the triggering of the connection monitor of all connected LSM-81, in case the MDP-810 in the control room has a faulty internet connection or is simply not accessible. In this case the corresponding action of the LSM-81 would not improve the condition.

Depending on the activated options, a trigger of the connection monitor will lead to the following actions:

- The modem core of the LSM-81 will restart. The LSM will now start a new registration to the network and potential connection problems could be eliminated.
- An SMS notification about the faulty internet connection will be sent to a preconfigured recipient. Another SMS will be sent as soon as the connection is reestablished.

**Remark when using M2M-SIM Cards:**

The following points need to be considered when M2M SIM cards are being used, which allow the communication within an isolated VPN Network:

- The device can be configured in a way that only communication via VPN is permitted and the access to the internet is denied. In this case the additional test for the internet connectivity cannot be performed and the connection monitor already triggers when the time runs out after there was no communication with a preconfigured MDP-810 for given time.
- The frequency of the transmission of the heartbeat telegrams can be prolonged to 5 minutes under "M2M-SIM" in the menu. A provider firewall does not have to stay open in this case and this reduces the data usage.

In this case the timeout timer of the connection monitor should be set to 6 minutes to avoid faulty triggers of the monitor.

### 5.3 Setting up the connection to an MDP-810

The set up the connection to one or two MDP-810 can be done under "GSM/LTE" → "Configuration":

The screenshot displays the 'LSM-81 configuration panel' for Funk-Electronic Piciorgros GmbH. On the left is a navigation menu with options: Login: user (Logout), Device, GSM / LTE (highlighted with a red arrow), Configuration, Phonebook, Alarm configuration, Binary alarms, Analog alarms, Status, IP settings, RTU features, and Service. The main area is divided into three sections:

- GSM/LTE Configuration:** Own telephone number (+4917212345678), SIM PIN (4711 [4 digit]).
- LTE IP communication:** APN (internet), Activate LTE-IP (radio buttons: Off, On), Internet connection monitor timeout (min) (1 [1 - 60]), Re-Register to LTE at expiry (radio buttons: Off, On), Send notification at expiry (radio buttons: Off, On), Send notification when OK again (radio buttons: Off, On).
- MDP-810 connection (highlighted with a red box):** MDP radio layer address (4713 [1 - 65500]), LSM-81 slave address (16 [1 - 239]), Primary MDP FQDN/IP (cloud.fep.de), Primary MDP Port (8110 [1 - 65500]), Secondary MDP FQDN/IP (cloud.fep.de), Secondary MDP Port (8111 [1 - 65500]), M2M SIM (Private VPN) (radio buttons: Off, On), MDP connection monitor timeout (min) (1 [1 - 60]), Send notification at expiry (radio buttons: Off, On), Send notification when OK again (radio buttons: Off, On).

For security purposes and to avoid and unwanted connection between the LSM-81 and the MDP-810, the following parameters have to be configured:

- The radio layer address of the MDP-810 masters has to be configured within the LSM-81. This radio layer address muss be identical for both MDP-810s (redundancy operation).
- The entered slave address in the LSM-81 has to be identical to the station address in the MDP-810.
- The serial number of the LSM-81 has to be inserted in the configuration for the station in the MDP-810. This ensures that only given LSM-81 will be permitted as a substation of the MDP-810.

Communication between the MDP-810(s) and the LSM-81 is only possible, when all three parameters match.

Configuration Point	Description
Connection the MDP-810	
MDP-Radio Layer Address	The radio layer address has to be added here, which the MDP-810 uses. If there is a mismatch the connection will be rejected by the MDP-810.
LSM-81 Slave Address	Configures the logical slave address of the LSM-81 in the MDP-810. This station has to be configured as "LSM-81" within the MDP-810 and the serial number has to be inserted.
Primary MDP FQDN/IP	The IP address or FQDN (Fully Qualified Domain Name) has to be inserted here, under which the primary MDP-810 can be reached.  No entry in this field will deactivate the connection.
Primary MDP Port	The port number of the UDP ports used to reach the primary MDP-810.  Port number 0 will deactivate the connection. Factory default: 8110.
Secondary MDP FQDN/IP	The IP address or FQDN (Fully Qualified Domain Name) has to be inserted here, under which the secondary MDP-810 can be reached.  No entry in this field will deactivate the connection.  In case the master is not working in redundant operation, no entry is necessary in this field.
Secondary MDP Port	The port number of the UDP ports used to reach the secondary MDP-810.  Port number 0 will deactivate the connection. Factory default: 8110.
M2M SIM	Under normal circumstances (Switched to "off") the LSM-81 will send out a heartbeat every 45 seconds to each preconfigured MDP-810 to keep the provider firewall open.  When special M2M SIM cards are in use without an existing firewall, the connection is established through an enclosed VPN. The heartbeat can be prolonged to 5 minutes in this case (set switch to "on") to decrease the data usage.
MDP-Connection monitor Timeout (Min)	The LSM-81 constantly monitors the connection to the MDP-810(s). An SMS notification will be sent out by the LSM-81 to a preconfigured recipient if the connection to the MDP-810(s) is lost for the time mentioned here. More details below.  Default Value: 5 Minutes
Send notification at expiry	If switch to „on“, an SMS notification will be send out to a preconfigured recipient (see below) once the timeout expires.
Send notification when ok again	If switch to „on“, another SMS notification will be send out to a preconfigured recipient once the connection is back up and running.  This option is only visible when "Send notification at expiry" is switched to "on" as well.

### 5.3.1 MDP-Connection Monitor

The connection monitor will be enabled if at least one connection to an MDP-810 has been configured. It consists of a timer with a value of 1 to 60 minutes. The value is set to 5 minutes by default.

As long as at least one MDP-810 is “online”, meaning the MDP-810 responds to the heartbeat telegrams correctly and authenticates the LSM-81, this timer will be reset constantly.

If no MDP-810 is active within the configured timeout time, no SMS notification can be sent to the preconfigured recipient.

An SMS notification can be sent to the preconfigured recipient after the connection is back up and running.

## 5.4 MoP Push (Request polling at input change)

To save data volume the LSM-81 will not be constantly polled by the MDP-810. The interval can be configured for each station individually in the MDP-810. By default, the interval is set to 60 seconds.

If a value changes in the command direction of the LSM-81, the MDP-810 will swiftly transmit the changes to the LSM-81. The MDP-810 will ignore the preset time lag to send out the command to the outstation immediately.

A similar behavior can be enforced with the „MoP Push“ function. Under menu point "RTU-Features" → "MoP Push", this feature can be enabled. From now on changes in any of the selected first 64 binary inputs and alarm blocks will result in the LSM-81 sending a request to the MDP-810 to poll the station immediately to receive the changes made.

The time between two push notifications can be limited to a value of 15-120 seconds to avoid constant sending of MoP Push requests if values are changing permanently. If the value is set to 20, the LSM-81 will wait 20 seconds before sending out the next MoP Push request. The LSM-81 will remember any changes within the time, when it is not allowed to send out push requests, and send the data after the timer is expired.

Through a collection delay, multiple push events can be stacked if changes in input values occur in a short timeframe. The values range from 0 (deactivated) to 10 seconds.

If collection delay is active, a timer will trigger after the first push event. All push events in the preconfigured timeframe will be collected and sent out to the MDP-810 after the delay timer runs out.

## LSM-81 configuration panel

Funk-Electronic Piciorgros GmbH - LSM-81

Login: user  
[Logout](#)

Device

GSM / LTE

IP settings

RTU features

Setup

Binary Inputs

Counters

**MoP Push** ←

Service

### MoP Push Configuration

Selected binary inputs / alarm blocks will send a push notification to an MDP-810 master if they change their state.

LSM-81 port A  0  1  2  3  4  5  6  7

Binary alarms  01  02  03  04  05  06  07  08

Binary alarms  09  10  11  12  13  14  15  16

Binary alarms  17  18  19  20  21  22  23  24

Analog alarms  01  02  03  04  05  06  07  08

Analog alarms  09  10  11  12  13  14  15  16

Min time between pushes (s)  [15 - 120]

Collection delay (s)  [0 - 10]

[Reset](#) [Apply](#)

Configuration Point	Description
LTE IP-Communication	
LSM-81 port A PEM port x	Here the monitored binary inputs are selected. Each ticked binary input will result in a push notification after a change was detected.
Binary Alarms	Here the monitored binary alarm blocks are selected. Each ticked binary alarm block will result in a push notification after a change was detected.
Analog Alarms	Here the monitored analog alarm blocks are selected. Each ticked alarm block will result in a push notification after the block was triggered.
Min time between pushes (s)	Time in seconds that has to be reached before a second push notification will be send out. If another push event occurs before the timer has run out, the push notification will only be sent to the MDP-810 after the expiration of the timer.  Factory default: 15 Seconds
Collection Delay (s)	If collection delay is active, a timer will trigger after the first push event. All push events in the preconfigured timeframe will be collected and sent out to the MDP-810 after the delay timer runs out.  Factory default: 0 Seconds (deactiavted)

### 5.5 Device information on connection status and data usage

The status and condition of the LTE connection, the connection to the MDP-810 and the data usage can be found under "GSM/LTE" → "Status":

## LSM-81 configuration panel

Funk-Electronic Piciorgros GmbH - LSM-81

<table border="1" style="width: 100%; border-collapse: collapse;"> <tr> <td style="background-color: #4a86e8; color: white; padding: 2px;">Login: user</td> </tr> <tr> <td style="text-align: center; padding: 2px;"><input type="button" value="Logout"/></td> </tr> <tr> <td style="background-color: #4a86e8; color: white; padding: 2px;">Device</td> </tr> <tr> <td style="background-color: #4a86e8; color: white; padding: 2px;">GSM / LTE</td> </tr> <tr> <td style="padding: 2px;">Configuration</td> </tr> <tr> <td style="padding: 2px;">Phonebook</td> </tr> <tr> <td style="padding: 2px;">Alarm configuration</td> </tr> <tr> <td style="padding: 2px;">Binary alarms</td> </tr> <tr> <td style="padding: 2px;">Analog alarms</td> </tr> <tr> <td style="padding: 2px; background-color: #4a86e8; color: white;">Status</td> </tr> <tr> <td style="padding: 2px;">IP settings</td> </tr> <tr> <td style="padding: 2px;">RTU features</td> </tr> <tr> <td style="padding: 2px;">Service</td> </tr> </table>	Login: user	<input type="button" value="Logout"/>	Device	GSM / LTE	Configuration	Phonebook	Alarm configuration	Binary alarms	Analog alarms	Status	IP settings	RTU features	Service	<table border="1" style="width: 100%; border-collapse: collapse;"> <tr> <td colspan="2" style="background-color: #4a86e8; color: white; padding: 2px; text-align: center;"><b>Device information</b></td> </tr> <tr> <td style="padding: 2px;">LTE engine version:</td> <td style="padding: 2px;">20.00.416</td> </tr> <tr> <td style="padding: 2px;">IMSI:</td> <td style="padding: 2px;">262072026343351</td> </tr> <tr> <td style="padding: 2px;">IMEI:</td> <td style="padding: 2px;">356530112810409</td> </tr> <tr> <td style="padding: 2px;">Registration status</td> <td style="padding: 2px;">Registered, home network</td> </tr> <tr> <td style="padding: 2px;">Cell name</td> <td style="padding: 2px;">Simply</td> </tr> <tr> <td style="padding: 2px;">Cell channel</td> <td style="padding: 2px;">3350</td> </tr> <tr> <td style="padding: 2px;">Cell ID</td> <td style="padding: 2px;">454</td> </tr> <tr> <td style="padding: 2px;">Cell TAC</td> <td style="padding: 2px;">8D42</td> </tr> <tr> <td style="padding: 2px;">Cell net code</td> <td style="padding: 2px;">26203</td> </tr> <tr> <td colspan="2" style="background-color: #4a86e8; color: white; padding: 2px; text-align: center;"><b>Network information</b></td> </tr> <tr> <td style="padding: 2px;">Current network:</td> <td style="padding: 2px;">Simply</td> </tr> <tr> <td style="padding: 2px;">Field strength</td> <td style="padding: 2px;">-71 dBm</td> </tr> <tr> <td style="padding: 2px;">LTE modem IP</td> <td style="padding: 2px;">10.113.31.104</td> </tr> <tr> <td colspan="2" style="background-color: #4a86e8; color: white; padding: 2px; text-align: center;"><b>MDP-810 connection status</b></td> </tr> <tr> <td style="padding: 2px;">Primary MDP</td> <td style="padding: 2px; color: green;">Online, S/N: 2</td> </tr> <tr> <td style="padding: 2px;">Secondary MDP</td> <td style="padding: 2px; color: green;">Online, S/N: 1</td> </tr> <tr> <td colspan="2" style="background-color: #4a86e8; color: white; padding: 2px; text-align: center;"><b>LTE traffic counters</b></td> </tr> <tr> <td style="padding: 2px;">Today</td> <td style="padding: 2px;">235 kB</td> </tr> <tr> <td style="padding: 2px;">Yesterday</td> <td style="padding: 2px;">514 kB</td> </tr> <tr> <td style="padding: 2px;">This month</td> <td style="padding: 2px;">12682 kB</td> </tr> <tr> <td style="padding: 2px;">Last month</td> <td style="padding: 2px;">7217 kB</td> </tr> </table>	<b>Device information</b>		LTE engine version:	20.00.416	IMSI:	262072026343351	IMEI:	356530112810409	Registration status	Registered, home network	Cell name	Simply	Cell channel	3350	Cell ID	454	Cell TAC	8D42	Cell net code	26203	<b>Network information</b>		Current network:	Simply	Field strength	-71 dBm	LTE modem IP	10.113.31.104	<b>MDP-810 connection status</b>		Primary MDP	Online, S/N: 2	Secondary MDP	Online, S/N: 1	<b>LTE traffic counters</b>		Today	235 kB	Yesterday	514 kB	This month	12682 kB	Last month	7217 kB
Login: user																																																										
<input type="button" value="Logout"/>																																																										
Device																																																										
GSM / LTE																																																										
Configuration																																																										
Phonebook																																																										
Alarm configuration																																																										
Binary alarms																																																										
Analog alarms																																																										
Status																																																										
IP settings																																																										
RTU features																																																										
Service																																																										
<b>Device information</b>																																																										
LTE engine version:	20.00.416																																																									
IMSI:	262072026343351																																																									
IMEI:	356530112810409																																																									
Registration status	Registered, home network																																																									
Cell name	Simply																																																									
Cell channel	3350																																																									
Cell ID	454																																																									
Cell TAC	8D42																																																									
Cell net code	26203																																																									
<b>Network information</b>																																																										
Current network:	Simply																																																									
Field strength	-71 dBm																																																									
LTE modem IP	10.113.31.104																																																									
<b>MDP-810 connection status</b>																																																										
Primary MDP	Online, S/N: 2																																																									
Secondary MDP	Online, S/N: 1																																																									
<b>LTE traffic counters</b>																																																										
Today	235 kB																																																									
Yesterday	514 kB																																																									
This month	12682 kB																																																									
Last month	7217 kB																																																									

Configuration Point	Description
Network Information	
LTE-Modem-IP	Shows the IP address of the LSM-81 in the LTE network. If there is no active LTE connection, 0.0.0.0 will be shown here.
MDP-810-Connection Status	
Primary MDP	The connection state to a preconfigured primary MDP-810 is displayed here.  If the connection is active, the serial number of the MDP-810 will be seen.
Secondary MDP	The connection state to a preconfigured secondary MDP-810 is displayed here.  If the connection is active, the serial number of the MDP-810 will be seen.
LTE Traffic Counter	
Today Yesterday This Month Last Month	Indicates the data usage of the LSM-81 in given timeframe in Kilobyte.

## 6 Supervision via MMI

---

Binary outputs can be controlled and inputs and parameters can be polled via so called MMI commands. This is how remote controlling of pumps, lights or the opening of doors is possible.

### 6.1 Basic configuration of the MMI access

To use MMI commands, this function has to be permitted explicitly. A 4-digit PIN number has to be determined, which has to be sent with every command. Only when PIN in the command and in the device match, the command will be carried out by the LSM-81. By default, the PIN is 4711.

If further security is desired, the execution of MMI commands can be limited to a number of participants, that are listed in the phone book. Commands from others will not be carried out, even when the PIN matches.

This configuration can be found here: ["GSM/LTE" → "Alarm configuration"](#).

### 6.2 Format of MMI Commands

The MMI commands contain a command header as well as a command section, which can include one or more MMI commands. When polled the LSM-81 sends a reply in MMI format back to the sender. An acknowledgement reply can explicitly be requested, even when the command (sent to the LSM) only contains a control action.

The MMI format sent to the LSM-81 is:

```
#M#1-PIN-[Command]
```

Whereas PIN is the 4-digit PIN number configured in the LSM. The command to request the field strength of the LSM-81 with the PIN 4711 is:

```
#M#1-4711-RF=?
```

The reply format of the LSM-81 is:

```
#M#2-0000-[Reply]
```

In case of field strength polling:

```
#M#2-0000-RF=-75dBm
```

### 6.2.1 Multiple commands in one SMS

Multiple commands can be sent in one MMI. The individual commands are comma separated. The following MMI message:

```
#M#1-4711-C0=1,RF=?,A0=?
```

Turns on output C0, requests the receiving field strength as well as the condition of binary input A0. A possible reply could be:

```
#M#2-0000-RF=-75dBm,A0=1
```

## 6.3 MMI Commands

### 6.3.1 A – Polling the binary input of the first port

Polling the binary input of port A	
Request format	Ax=?
Reply format	Ax=0   Ax=1
<p>The command polls the binary inputs x (0-7) for port A of the LSM-81. If the input is active, the reply will be "Ax=1", otherwise "Ax=0".</p>	

### 6.3.2 AB=? – Poll a binary input

Poll first 16 Binary Inputs	
Request format	AB=?
Reply format	A=xx ; B=xx
<p>This command polls the first 16 binary inputs and provides the result in two hexadecimal values. Here Bit 0 is the first input and Bit 7 the last one of each group.</p> <p>When using an LSM-81 without expansion modules, the requested value for "B" will always "00". Only when a PEM with 16 binary inputs is connected to the LSM, the value of the first port of "B" will be sent back.</p>	

### 6.3.3 AI=? – Polling an analog input

Polling an analog input	
Request format	AIx=?
Reply format	AIx=y
<p>This command requests the value of analog input x and provides the raw value “y” of the analog converter in the range of 0 (0mA) until 4095 (20mA). The first analog input D0 has the number “0”.</p>	
<p>Request format</p> <p>AIx%=?</p>	
Reply format	AIx=y[unit]
<p>This command requests the value of analog input x and provides a scaled result, if possible. The first analog input D0 has the number “0”.</p> <p>For the scaling the LSM browses for analog alarm blocks that use the requested alarm input. If such alarm input is found, the LSM will use the stored scaling for the output of the value.</p> <p>If the analog alarm block 1 has been configured for the analog input 0 (range from 0-30) with the unit “m3”, a possible reply could be:</p> <p>#M#1-4711-AI0%=?</p> <p>#M#2-0000-AI0=14.030m3</p> <p>If no message block for the scaling is found, the reply will show the value in percent.</p>	

**6.3.4 C – Polling or setting a binary input of the first port**

Poll binary input Port C	
Request format	Cx=?
Reply format	ACx=0   Cx=1
The command polls binary output x (0-7) of Port C. If the output is active the reply will be "Cx=1" otherwise "Cx=0".	

Switch binary output Port C	
Request format	Cx=0   Cx=1
Reply format	No reply
This command activates (Cx=1) or deactivates (Cx=0) the binary output of Port C of the LSM-81.	

**6.3.5 CD=? – Polling binary outputs**

Poll first 16 binary outputs	
Request format	CD=?
Reply format	C=xx; D=xx
This command polls the first 16 binary outputs and provides the result in two hexadecimal values. Here Bit 0 is the first output and Bit 7 the last one of each group.	
When using an LSM-81 without expansion modules, the requested value for "D" will always "00". Only when a PEM with 16 binary outputs is connected to the LSM, the value of the first port of "B" will be sent back.	

### 6.3.6 CP – Set or request value of cost protection

Request value of cost protection	
Request format	CP=?
Reply format	CP=x   CP=UL
<p>Requests the status of the cost protection. The number of remaining alarms for the ongoing day will be sent back.</p> <p>When cost protection for the LSM-81 is deactivated, the reply will be "CP=UL" (Unlimited).</p>	

Set cost protection	
Request format	CP=x
Reply format	CP=x   CP=UL
<p>Sets the costs protection to x remaining alarms for the ongoing day.</p> <p>The new value cannot exceed the configured daily limit in the device. If a higher value is entered, it will be automatically reduced to the daily limit.</p> <p>When cost protection for the LSM-81 is deactivated, the value will not be set and the reply will be "CP=UL" (Unlimited).</p>	

### 6.3.7 DI – Polling binary input

Polling binary inputs port A	
Request format	DI <sub>x</sub> =?
Reply format	DI <sub>x</sub> =0   DI <sub>x</sub> =1
<p>The command polls the binary input x (0-255).</p> <p>Is the input active, the reply will be "DI<sub>x</sub>=1", otherwise "DI<sub>x</sub>=0".</p> <p>Input 0 is the first input of the LSM-81, the following binary inputs can be polled in ascending order. "DI8" is the first inputs of the first Port of the first expansion module with binary inputs.</p> <p>If the polled binary input is physically not available, the error reply will be "DI<sub>x</sub>=???" and the processing of consecutive command may be terminated.</p>	

### 6.3.8 DO –Polling or setting a binary output

Polling a binary output	
Request format	DOx=?
Reply format	DOx=0   DOx=1
<p>The command polls the binary outputs x (0-255).</p> <p>Is the output active, the reply will be "DOx=1", otherwise "DOx=0".</p> <p>Output 0 is the first output of the LSM-81, the following binary outputs can be polled in ascending order. "DO8" is the first outputs of the first Port of the first expansion module with binary outputs.</p> <p>If the polled binary output is physically not available, the error reply will be "DOx=???" and the processing of consecutive command may be terminated.</p>	

Setting a binary output	
Request format	DOx=0   DOx=1
Reply format	No reply
<p>The command activates binary output X (DOx=1) or deactivates it (DOx=0).</p> <p>Output 0 is the first output of the LSM-81, the following binary outputs can be polled in ascending order. "DO8" is the first inputs of the first Port of the first expansion module with binary outputs.</p> <p>With this, all existing binary outputs at the LSM-81 can be accessed.</p> <p>If the polled binary output is physically not available, the error reply will be "DOx=???" and the processing of consecutive command may be terminated.</p>	

**6.3.9 PU – Pulse output of binary outputs**

Pulse output of binary outputs	
Request format	PUx=t
Reply format	No reply
<p>An Impulse with the duration of "t" seconds (1-25) can be issued to binary output x (0-39).</p> <p>Output 0 is the first binary output of the LSM-81 (Port C0) and only the first 40 binary outputs can be used for pulse outputs in the system.</p> <p>If the polled binary output is physically not available, an error reply will be sent and the processing of consecutive command may be terminated.</p>	

**6.3.10 Q – Enforce or suppress Acknowledgements**

Enforce or suppress Acknowledgements	
Request format	Q=1   Q=0
Reply format	No direct reply to command
<p>With command "Q=1" an acknowledgement is enforced even when no direct reply is requested by the command. In this case an empty telegram "#M#2-0000". will be the reply. Here a reply can be enforced even when a command e.g. "C0=1" does not request one.</p> <p>With command "Q=0" the acknowledgement will be suppressed, even when the LSM-81 receives a request to reply.</p>	

**6.3.11 R – Request register value**

Request register value	
Request format	Rx=?
Reply format	Rx=YYYY
<p>This command polls the value of an internal register x and displays the value in a 4-digit hexadecimal value.</p> <p>This function can be used for support purposes.</p>	

**6.3.12 RF – Requesting field strength**

Requesting field strength	
Request format	RF=?
Reply format	RF=-x dBm
This command requests the current receiving field strength of the cellular network of the LSM-81. The reply is displayed in -dBm.	

**6.3.13 SN=? – Request Serial Number**

Request Serial Number	
Request format	SN=?
Reply format	SN=x
The command requests the serial number of the LSM-81.	

**6.3.14 Z=1 – Adding Time Stamp**

Adding Time Stamp	
Request format	Z=1
Reply format	No reply
<p>Adds the time stamp to the MMI reply of the LSM-81. The simple command "Z=1" will not lead to a reply by the LSM-81, so another command needs to be part of the MMI.</p> <p>The time stamp is always displayed directly after „2-000“. It contains of 12 digits and the format is YYMMDDhhmmss.</p> <p>If the time stamp is requested, one possible command could be:</p> <p>Z=1, Q=1</p> <p>The reply could be:</p> <p>2-0000-220324080423</p> <p>A command request with time stamp could be:</p> <p>#M#1-4711-Z=1, RF=?</p> <p>#M#2-0000-220324084236, RF=-79dBm</p>	

### 6.4 Remote controlling between LSM-81s using MMI

Remote controls between two LSM-81 can be performed using MMIs. An example can be seen below:

An overhead tank should turn on the pump if the water level undergoes 5m3 and turn off the pump once 25m3 are reached. On both sides an LSM-81 is installed.

The LSM-81 "pump" should acknowledge the switch command. If the sending LSM-81 does not receive the acknowledgement within 30 seconds, the command should be repeated twice. If the command has still not been acknowledged afterwards, a supervisor should be informed.

For this application we will use an analog alarm block with acknowledgement. The message text in this case is the MMI command for LSM-81 „pump“, which will turn on the pump. Two analog alarm blocks will be needed. One, which will turn on the pump when 5m3 is undergone and one, which will turn it off again, once 25m3 is reached.

To realize the repetition if no acknowledgement is sent, the phone number of LSM-81 “pump” is entered in the phone book of the LSM-81 “Overhead Tank” 3 times:

**LSM-81 configuration panel**  
Funk-Electronic Piciorgros GmbH

**Login:**  
fepadmin

**Device**

- GSM / LTE
- Configuration
- Phonebook** ←
- Alarm configuration
- Binary alarms
- Analog alarms
- Status

**IP settings**

**RTU features**

**Service**

Phonebook		
Index	Number (+xxxxx)	Name
Supervisor	+ 4917308150815	Dagobert Duck
1	+ 49171543210	LSM Pumpe
2	+ 49171543210	LSM Pumpe
3	+ 49171543210	LSM Pumpe
4	+ 0	
5	+ 0	
6	+ 0	
7	+ 0	
8	+ 0	
9	+ 0	
10	+ 0	
11	+ 0	
12	+ 0	
13	+ 0	
14	+ 0	
15	+ 0	
16	+ 0	
17	+ 0	
18	+ 0	
19	+ 0	
20	+ 0	
21	+ 0	
22	+ 0	
23	+ 0	
24	+ 0	
25	+ 0	

**Supervisor:**  
Dieser Teilnehmer erhält eine Nachricht, wenn eine Steuermeldung nicht vom entfernten LSM-81 quittiert wurde.

**Telefonbuch:**  
Die Nummer des LSM-81, an welchem die Pumpe angeschlossen ist, wird 3 Mal hintereinander in das Telefonbuch eingetragen. Hierdurch kann die Steuermeldung bis zu 2 Mal wiederholt gesendet werden!

The first analog alarm block "Turn on pump" will be configured as follows:

**LSM-81 configuration panel**  
Funk-Electronic Piciorgros GmbH

**Analog alarms**  
Alarm (1-16)

**Alarm #1 configuration**

Alarm text:

On-delay (s):  [0 - 60]

Realarm delay (min):  [0 - 60]

Alarm type:  Normal  Priority

Acknowledgement:  Off  On

Alarm timing:  Sequential  Parallel

ACK wait time (s):  [15 - 90]

Alarm activation:  Always  Time window

Add time stamp:  Off  On

Add device name:  Off  On

First alarm recipient:

Last alarm recipient:

**Alarm #1 activation parameters**

Trigger input:

Scaling low:  [-9999.000 - 9999.000]

Scaling high:  [-9999.000 - 9999.000]

Hysteresis:  [0.000 - 999.000]

Unit:

Trigger value:  [-9999.000 - ...]

Sensor type:  0-20mA  4-20mA

Activation criteria:

The second analog message block "Turn off pump" is configured as:

The screenshot displays the LSM-81 configuration panel for 'Meldeblock 2'. The left sidebar shows navigation options: Login: fepadmin, Logout, Device, GSM / LTE, Configuration, Phonebook, Alarm configuration, Binary alarms, Analog alarms (highlighted), Status, IP settings, RTU features, and Service. The main area is divided into two sections:

- Alarm #2 configuration:**
  - Alarm text: #M#1-4711-C0=0,Q=1 (Callout: MMI-Befehl zur Deaktivierung des Ausgangs C0 und Anforderung einer Quittung)
  - On-delay (s): 0 [0 - 60]
  - Realarm delay (min): 0 [0 - 60]
  - Alarm type:  Normal  Priority
  - Acknowledgement:  Off  On (Callout: Sequentielle Alarmierung mit Quittung und einer Wartezeit von 30 Sekunden zwischen den SMS)
  - Alarm timing:  Sequential  Parallel
  - ACK wait time (s): 30 [15 - 90]
  - Alarm activation:  Always  Time window
  - Add time stamp:  Off  On
  - Add device name:  Off  On
  - First alarm recipient: 1 | +49171543210 | LSM Pumpe
  - Last alarm recipient: 3 | +49171543210 | LSM Pumpe (Callout: Die Teilnehmer 1-3 aus dem Telefonbuch werden alarmiert. Da alle Einträge die gleiche Nummer des entfernten LSM-81 sind, wird bis zu 2 Mal wiederholt, wenn die Quittung ausbleibt.)
- Alarm #2 activation parameters:**
  - Trigger input: LSM-81 D0 (Callout: Konfiguration der Sensorparameter)
  - Scaling low: 0.000 [-9999.000 - 9999.000]
  - Scaling high: 30.000 [-9999.000 - 9999.000]
  - Hysteresis: 0.500 [0.000 - 999.000] (Callout: Schaltschwelle 25m3)
  - Unit: m3
  - Trigger value: 25.000 [-9999.000 - 9999.000] (Callout: Auslösen bei Überschreitung)
  - Sensor type:  0-20mA  4-20mA
  - Activation criteria: Exceedance

Notice:

- If an alarm text start with "#M#", the reply will always be without time stamp and device name, even if it was preconfigured in the alarm block. Even the text "Please acknowledge" will be suppressed.
- The maximal "Life time" of an MMI-SMS (Starting with "#M#") in the SMS control center is five minutes. This is to prevent an old unreceived SMS (e.g. due to a device power down) to be sent hours or days later. It is not guaranteed that the SMS center of the cellular network operator supports this parameter. Please check with your provider.

## 7 RTU Functionality

---

The LSM-81 can function as a remote station in conjunction with an MDP-810. Up to 64 LSM-81 can be linked to an MDP-810 controller, with up to 16 PEM I/O expansion modules each.

A PLC or SCADA server from a control room can interchange data via the MODBUS/IP or MODBUS/RTU protocol from an MDP controller to the outstations. I/Os from PEM expansion modules connected to the MDP-810 can be routed to the LSM-81s or RTU-810s in the field using PiRangia.

When using an MDP-810 the transmission modes can be mixed so that radio outstations (RTU-810/TRM-810) and LSM-81s can be interlinked within the same MDP-810.

Configurable virtual inputs and outputs can be used in addition to the physical I/Os. These are 16-bit registers that can be read or written via the MODBUS/IP or MODBUS/RTU protocol by a device (e.g. PLC) which is physically connected to an LSM-81 (e.g. a PLC). This is how up to 40 16-bit long words can be interchanged via a device connected to the LSM-81 and an MDP-810 connected to the control room.

## 7.1 Configuration of Inputs and Outputs

The menu "RTU features" offers the user the ability to configure the characteristics of the inputs and outputs.

### 7.1.1 Virtual analog inputs and outputs, Monitoring

Via "RTU features" → "Setup" the virtual analog inputs and outputs as well as the monitoring of the inputs and outputs can be configured:

## LSM-81 configuration panel

Funk-Electronic Piciorgros GmbH - LSM-81 Stoermelder

<div style="background-color: #4a86e8; color: white; padding: 2px;">Login: user</div> <div style="background-color: #4a86e8; color: white; padding: 2px; text-align: center;">Logout</div> <div style="background-color: #4a86e8; color: white; padding: 2px;">Device</div> <div style="background-color: #4a86e8; color: white; padding: 2px;">GSM / LTE</div> <div style="background-color: #4a86e8; color: white; padding: 2px;">IP settings</div> <div style="background-color: #4a86e8; color: white; padding: 2px;">RTU features</div> <div style="background-color: #4a86e8; color: white; padding: 2px;">Setup</div> <div style="background-color: #4a86e8; color: white; padding: 2px;">Binary Inputs</div> <div style="background-color: #4a86e8; color: white; padding: 2px;">Counters</div> <div style="background-color: #4a86e8; color: white; padding: 2px;">Service</div>	<table border="1" style="width: 100%; border-collapse: collapse;"> <thead> <tr style="background-color: #4a86e8; color: white;"> <th colspan="2">I/O Information</th> </tr> </thead> <tbody> <tr><td>Binary inputs</td><td style="text-align: right;">24</td></tr> <tr><td>Analog inputs</td><td style="text-align: right;">2</td></tr> <tr><td>Binary outputs</td><td style="text-align: right;">24</td></tr> <tr><td>Analog outputs</td><td style="text-align: right;">0</td></tr> <tr><td>Counters</td><td style="text-align: right;">8</td></tr> </tbody> </table> <table border="1" style="width: 100%; border-collapse: collapse; margin-top: 5px;"> <thead> <tr style="background-color: #4a86e8; color: white;"> <th colspan="2">Virtual analog I/O</th> </tr> </thead> <tbody> <tr> <td>Virt. analog in</td> <td><input style="width: 80px;" type="text" value="0"/> [0 - 40]</td> </tr> <tr> <td>Virt. analog out</td> <td><input style="width: 80px;" type="text" value="0"/> [0 - 40]</td> </tr> </tbody> </table> <table border="1" style="width: 100%; border-collapse: collapse; margin-top: 5px;"> <thead> <tr style="background-color: #4a86e8; color: white;"> <th colspan="2">RTU setup</th> </tr> </thead> <tbody> <tr> <td>Binary Input Monitoring</td> <td><input type="radio"/> On <input checked="" type="radio"/> Off</td> </tr> <tr> <td></td> <td><input style="width: 80px;" type="text" value="0"/></td> </tr> <tr> <td>Analog Input Monitoring</td> <td><input type="radio"/> On <input checked="" type="radio"/> Off</td> </tr> <tr> <td></td> <td><input style="width: 80px;" type="text" value="0"/></td> </tr> <tr> <td>Binary Output Monitoring</td> <td><input type="radio"/> On <input checked="" type="radio"/> Off</td> </tr> <tr> <td></td> <td><input style="width: 80px;" type="text" value="0"/></td> </tr> <tr> <td>Analog Output Monitoring</td> <td><input type="radio"/> On <input checked="" type="radio"/> Off</td> </tr> <tr> <td></td> <td><input style="width: 80px;" type="text" value="0"/></td> </tr> <tr> <td>Counter Monitoring</td> <td><input type="radio"/> On <input checked="" type="radio"/> Off</td> </tr> <tr> <td></td> <td><input style="width: 80px;" type="text" value="0"/></td> </tr> </tbody> </table> <table border="1" style="width: 100%; border-collapse: collapse; margin-top: 5px;"> <thead> <tr style="background-color: #4a86e8; color: white;"> <th colspan="2">Timeout values</th> </tr> </thead> <tbody> <tr> <td>X-Timeout</td> <td><input type="radio"/> On <input checked="" type="radio"/> Off</td> </tr> <tr> <td></td> <td><input style="width: 80px;" type="text" value="0"/> cycles</td> </tr> <tr> <td>T-Timeout</td> <td><input type="radio"/> On <input checked="" type="radio"/> Off</td> </tr> <tr> <td></td> <td><input style="width: 80px;" type="text" value="0"/> sec</td> </tr> </tbody> </table> <div style="text-align: right; margin-top: 5px;"> <input type="button" value="Reset"/> <input type="button" value="Apply"/> </div>	I/O Information		Binary inputs	24	Analog inputs	2	Binary outputs	24	Analog outputs	0	Counters	8	Virtual analog I/O		Virt. analog in	<input style="width: 80px;" type="text" value="0"/> [0 - 40]	Virt. analog out	<input style="width: 80px;" type="text" value="0"/> [0 - 40]	RTU setup		Binary Input Monitoring	<input type="radio"/> On <input checked="" type="radio"/> Off		<input style="width: 80px;" type="text" value="0"/>	Analog Input Monitoring	<input type="radio"/> On <input checked="" type="radio"/> Off		<input style="width: 80px;" type="text" value="0"/>	Binary Output Monitoring	<input type="radio"/> On <input checked="" type="radio"/> Off		<input style="width: 80px;" type="text" value="0"/>	Analog Output Monitoring	<input type="radio"/> On <input checked="" type="radio"/> Off		<input style="width: 80px;" type="text" value="0"/>	Counter Monitoring	<input type="radio"/> On <input checked="" type="radio"/> Off		<input style="width: 80px;" type="text" value="0"/>	Timeout values		X-Timeout	<input type="radio"/> On <input checked="" type="radio"/> Off		<input style="width: 80px;" type="text" value="0"/> cycles	T-Timeout	<input type="radio"/> On <input checked="" type="radio"/> Off		<input style="width: 80px;" type="text" value="0"/> sec
I/O Information																																																			
Binary inputs	24																																																		
Analog inputs	2																																																		
Binary outputs	24																																																		
Analog outputs	0																																																		
Counters	8																																																		
Virtual analog I/O																																																			
Virt. analog in	<input style="width: 80px;" type="text" value="0"/> [0 - 40]																																																		
Virt. analog out	<input style="width: 80px;" type="text" value="0"/> [0 - 40]																																																		
RTU setup																																																			
Binary Input Monitoring	<input type="radio"/> On <input checked="" type="radio"/> Off																																																		
	<input style="width: 80px;" type="text" value="0"/>																																																		
Analog Input Monitoring	<input type="radio"/> On <input checked="" type="radio"/> Off																																																		
	<input style="width: 80px;" type="text" value="0"/>																																																		
Binary Output Monitoring	<input type="radio"/> On <input checked="" type="radio"/> Off																																																		
	<input style="width: 80px;" type="text" value="0"/>																																																		
Analog Output Monitoring	<input type="radio"/> On <input checked="" type="radio"/> Off																																																		
	<input style="width: 80px;" type="text" value="0"/>																																																		
Counter Monitoring	<input type="radio"/> On <input checked="" type="radio"/> Off																																																		
	<input style="width: 80px;" type="text" value="0"/>																																																		
Timeout values																																																			
X-Timeout	<input type="radio"/> On <input checked="" type="radio"/> Off																																																		
	<input style="width: 80px;" type="text" value="0"/> cycles																																																		
T-Timeout	<input type="radio"/> On <input checked="" type="radio"/> Off																																																		
	<input style="width: 80px;" type="text" value="0"/> sec																																																		

Configuration Points	Description
I/O Information	
Binary inputs	Total amount of binary inputs including those of connected expansion modules
Analog inputs	Total amount of analog inputs including those of connected expansion modules
Binary outputs	Total amount of binary outputs including those of connected expansion modules
Analog outputs	Total amount of analog outputs including those of connected expansion modules
Counters	Number of event and time counters. The LSM-81 offers this as an additional function for the embedded 8 inputs.
Virtual analog I/O	
Virt. analog in	<p>Number of virtual analog inputs. These are registers, which can be read or written by a device connected to the LSM via MODBUS/IP or MODBUS/RTU.</p> <p>On the opposite side (e.g. an MDP-810) these 16-bit values appear as additional analog inputs of the substation.</p>
Virt. Analog out	<p>Number of virtual analog outputs. These are registers, which can be read by a device connected to the LSM via MODBUS/IP or MODBUS/RTU.</p> <p>On the opposite side (e.g. an MDP-810) these 16-bit values appear as additional analog outputs of the substation.</p>
RTU setup	
<p>Here the active monitoring for each I/O type can be configured. If the monitoring is active, the exact number of expected inputs or outputs of given type has to be entered into this field.</p> <p>If the number of actual inputs and outputs does not match the number of the active monitoring, there will be an I/O error. In this case all outputs of the LSM-81 will be put into a secure state (turned off).</p>	
Timeout values	
T-Timeout	<p>When the T-Timeout is active, periodic accesses to the LSM-81 has to take place either by MODBUS, MMI command or by data transmission from an RTU-810 within the given time.</p> <p>If this time runs out without access, all outputs of the LSM-81 will be put into a secure state (turned off).</p>

### 7.1.2 Delay of binary inputs of the LSM-81

The 8 binary inputs of the LSM can provide a turn-on or turn-on/off delay. The delay can be configured in 100ms units.

This delay has an effect on the hardware level, meaning prior to the logical functions like alarm blocks.

If an input has a turn-on-delay of 20 (2 seconds) configured and an alarm block, which uses this input, has a turn-on-delay of 3 seconds configured, the input has to be active for 5 seconds to release the alarm block.

The turn-on-delay also has an effect on the LEDs of the corresponding inputs

## LSM-81 configuration panel

Funk-Electronic Piciorgros GmbH - LSM-81 Stoermelder

Login: user

Device

GSM / LTE

IP settings

RTU features

Setup

Binary Inputs

Counters

Service

Binary Input Delays					
10 entries beginning with <input style="width: 50px;" type="text" value="1"/> <input type="button" value="Browse"/>					
Num	Input	Delay	Mode		
1	A0	<input style="width: 50px;" type="text" value="0"/> [x 100ms]	<input checked="" type="radio"/>	On/Off	<input type="radio"/> On
2	A1	<input style="width: 50px;" type="text" value="0"/> [x 100ms]	<input checked="" type="radio"/>	On/Off	<input type="radio"/> On
3	A2	<input style="width: 50px;" type="text" value="0"/> [x 100ms]	<input checked="" type="radio"/>	On/Off	<input type="radio"/> On
4	A3	<input style="width: 50px;" type="text" value="0"/> [x 100ms]	<input checked="" type="radio"/>	On/Off	<input type="radio"/> On
5	A4	<input style="width: 50px;" type="text" value="0"/> [x 100ms]	<input checked="" type="radio"/>	On/Off	<input type="radio"/> On
6	A5	<input style="width: 50px;" type="text" value="0"/> [x 100ms]	<input checked="" type="radio"/>	On/Off	<input type="radio"/> On
7	A6	<input style="width: 50px;" type="text" value="0"/> [x 100ms]	<input checked="" type="radio"/>	On/Off	<input type="radio"/> On
8	A7	<input style="width: 50px;" type="text" value="0"/> [x 100ms]	<input checked="" type="radio"/>	On/Off	<input type="radio"/> On

### 7.1.3 Configuration of Counters

Each binary input of the LSM has an additional function: a 16-bit counter. Each counter can be configured as event counter ("Counter") or time counter ("Timer").

The event counter counts impulses with a maximal frequency of 10 Hz. Each rising edge at the input is counted.

If the counter value reaches 65535 it will be zeroed with the next impulse. The setting back to zero has to be considered when the data is evaluated in the control room.

The time counter increases by one every second the input is active. The counter is also zeroed once the value reaches 65535.

The screenshot displays the LSM-81 configuration interface. At the top, a blue header reads "LSM-81 configuration pane" and "Funk-Electronic Piciorgros GmbH - LSM-81 Stoermelde". On the left, a vertical menu contains options: "Login: user" with a "Logout" button, "Device", "GSM / LTE", "IP settings", "RTU features", "Setup", "Binary Inputs", "Counters" (highlighted with a red arrow), and "Service". On the right, the "Counter configuration" section lists inputs A0 through A7. Each input has two radio buttons: "Counter" (selected) and "Timer". At the bottom right of this section are "Reset" and "Apply" buttons.

Input	Counter	Timer
A0	<input checked="" type="radio"/>	<input type="radio"/>
A1	<input checked="" type="radio"/>	<input type="radio"/>
A2	<input checked="" type="radio"/>	<input type="radio"/>
A3	<input checked="" type="radio"/>	<input type="radio"/>
A4	<input checked="" type="radio"/>	<input type="radio"/>
A5	<input checked="" type="radio"/>	<input type="radio"/>
A6	<input checked="" type="radio"/>	<input type="radio"/>
A7	<input checked="" type="radio"/>	<input type="radio"/>

## 7.2 Access via MODBUS protocol

The local access of the inputs and outputs, the virtual I/O's as well as the counters is possible via MODBUS protocol. This can be done via the serial interface or the IP application interface (MODBUS-RTU-Protocol) as well as via IP (MODBUS/TCP or MODBUS/UDP).

The settings of the parameters of the serial and IP application interface are described in chapter 7.1 and 7.2.

The access via MODBUS/IP is configured in menu "Device" → "Access"

**LSM-81 configuration panel**  
Funk-Electronic Piciorgros GmbH - LSM-81 Stoermelder

**Login: user**  
Logout

**Device**

- Common
- COM interface
- IP application interface
- Access** ←
- Internal clock

**GSM / LTE**

- IP settings
- RTU features
- Service

**Device Access Parameters**

Modbus IP Port	502
Active	<input type="radio"/> Off <input checked="" type="radio"/> On
IP Protocol	<input type="radio"/> UDP <input checked="" type="radio"/> TCP
Webserver Port	80
Internal TFTP Port	69

Reset Apply

Configuration Points	Description
Device Access Parameters	
Modbus IP port	Shows the TCP or UDP port used to access the device via MODBUS/IP protocol. By default, it is Port 502
Active	Activates or deactivates the access via MODBUS/IP
IP Protocol	Menu to choose between MODBUS/TCP and MODBUS/UDP
Webserver port	The port of the integrated webserver. By default, it is Port 80
Internal TFTP port	The internal TFTP port used to load or save the configuration and to update the device. By default, it is port 69.

### 7.2.1 Supported MODBUS Commands

These MODBUS commands are supported by the LSM-81:

Command	Description
1 (0x01)	Read Coil Status
2 (0x02)	Read Input Status
3 (0x03)	Read Holding Registers
4 (0x04)	Read Input Registers
5 (0x05)	Force Single Coil
6 (0x06)	Write Single Register
8 (0x08)	Sub 0: Local Loopback
15 (0x0F)	Force Multiple Coils
16 (0x10)	Preset Multiple Registers
23 (0x17)	Read/Write Multiple Registers

## 7.2.2 MODBUS-Register Addresses

Below, the register addresses for the MODBUS access are listed:

Register	Description
0	Individual device address
1	<p>High-Byte: Receiving field strength of LSM-81 in -dBm</p> <p>Low-Byte: Device status as listed below:</p> <ul style="list-style-type: none"> <li>• Bit 7: Is set when device restarts. This bit can be reset by writing a value to the register with bit 7 set.</li> <li>• Bit 6: A set bit means that an I/O error has occurred. This can be a malfunctioning or removed expansion module or an I/O monitoring value that does not match. This bit can be reset by writing a value to the register with bit 6 set. If the error still occurs, the write command will not reset bit 6.</li> <li>• Bit 5: The time is synchronized</li> <li>• Bit 3: Is set when the system time is correct</li> <li>• Bit 2: Is set when the device has no malfunctions</li> <li>• Bit 1: When this bit is set, there is a problem in the LTE module.</li> </ul>
2 – 199	<p>All inputs and counters in compact format in the following order:</p> <ul style="list-style-type: none"> <li>• Digital inputs</li> <li>• Analog Inputs (Physical first then virtual)</li> <li>• Counters</li> <li>• 32 virtual PicoLogo- input registers</li> </ul>
200 – 231	32 virtual input registers. These can be written by a PicoLogo application and can be read by the LSM-81 (e.g. by a SCADA)
232 – 263	32 virtual PicoLogo output registers. The can be written by an LSM-81 (e.g. by a SCADA) and can be read by a PicoLogo application
400 – 449 Reading	Digital inputs. The input A0 is the LSB of the first register, all other inputs in ascending order.
400 – 439 Writing	<p>Impulse output of the maximum first 40 binary outputs. Register 400 is output C0.</p> <p>By writing a value of 1-25 (seconds) in each respective register, a correspondingly long impulse will be issued at the corresponding binary output. If the value written in this register is higher than 25, 25 seconds will be used as the maximum value.</p>
450 – 599	<p>Analog inputs (if any) as 12-bit values.</p> <p>The top four bits are set to 0000.</p> <p>Virtual analog inputs (16 bit) are listed after the physical inputs.</p>
600 – 649	<p>Counters, 16 bit each.</p> <p>The first counter refers to I/O port A0 followed by A1...A7.</p>

Register	Description
650 – 689	Virtual analog inputs These can be read or written by a device connected to the LSM-81 and appear for an MDP-810 as analog inputs of an outstation.
700 – 739	Virtual analog outputs These can be read by a device connected to the LSM-81 and appear for an MDP-810 as analog outputs of an outstation.
750 – 799	Digital Outputs. The output C0 is the LSB of the first register, all other outputs in ascending order.
800 – 899	Analog Outputs (if any). Virtual analog outputs are listed after the physical outputs.

### 7.2.3 Special MODBUS Registers

Register	Function	Description
1000	Device ID	0x5000 for LSM-81
1001	Software-Version	Software-Version of the LSM-81. Version 01.23 is shown as 0x0123.
1004	Hardware-Revision	Hardware Revision number
1008	Serial Number	The serial number of the LSM-81
1010	Status/RSSI	Just as described under MODBUS address 1
1030	Time YYMM	Current time: Year (High Byte) and month (Low Byte)
1031	Time DDhh	Current time: day (High Byte) and hour (Low Byte)
1032	Time mmss	Current time: Minutes (High Byte) and seconds (Low Byte)
1033	Time weekday	Weekday, 1 (Monday) – 7 (Sunday)
1034	Time Status	<ul style="list-style-type: none"> <li>• Bit 0: 1=DST active</li> <li>• Bit 7: 1=time incorrect, has to be set (if ATS is active or the LSM is operating as a substation of an MDP-810, this is done automatically)</li> </ul>
1035	Set time YYMM	Set new value for year/month to set time
1036	Set time DDhh	Set new value for day/hour to set time
1037	Set time mmss	Set new value for minute/second to set time
1038	Set time	When bit 0 is set to 1 the values in registers 1035-1037 are written into the real-time clock
1507	T-Timeout	Value of T-Timeout
1510	Number of BE	Number of available binary inputs of the LSM- 81
1511	Number of AE	Number of available analog inputs of the LSM- 81
1512	Number of BA	Number of available binary outputs of the LSM- 81
1513	Number of AA	Number of available analog outputs of the LSM- 81
1514	Number of CNT	Number of available counters of the LSM- 81

#### 7.2.4 MODBUS coil and input commands

The binary I/O's as well as the 32 virtual PicoLogo I/O's can be accessed by using coil/input commands via the MODBUS protocol.

Coil / Input	Allocation
Coils 0 – 299	Binary hardware outputs of the LSM-81
Coils 1000 – 1031	32 virtual coils, which can be written by the SCADA or the master and which can be read/written by a PicoLogo application
Input 0 – 299	Binary hardware inputs of the LSM-81
Input 1000-1031	32 virtual inputs which can be written by a PicoLogo application and which can be read by a SCADA or a master.

## 8 Other functions

### 8.1 Serial interface

The serial interface can be used to access the LSM-81 via MODBUS-RTU protocol (to use the RTU functionality) or for the #-command mode (SMS gateway).

This can be configured in the webserver under "Device" → "COM interface":

The screenshot displays the LSM-81 configuration panel. On the left is a navigation menu with the following items: Login: fepadmin (Logout), Device (Common, COM interface, IP application interface, Access, Internal clock), GSM / LTE, IP settings, RTU features, and Service. A red arrow points to the 'COM interface' option in the 'Device' section. The main content area is titled 'COM interface Configuration' and includes the following settings:

- Port Operating mode:  Local: Modbus,  #-command mode,  None
- COM Port Serial Parameter Settings:
  - Baudrate: 9600 [300-57600 bit/s]
  - Databit:  8,  7,  6,  5
  - Parity:  None,  Even,  Odd
  - Stopbit:  1,  2
  - Handshake Control:  CTS,  CTS/RTS,  CTS line simulates DCD
  - Mode:  Timeout,  CR / LF,  3964R
  - Timeout: 10 [ms]

Buttons for 'Reset' and 'Apply' are located at the bottom of the configuration area.

Configuration Point	Description
COM interface configuration	
Port operating mode	<p>The operating mode of the interface can be configured here:</p> <ul style="list-style-type: none"> <li>• Local: Modbus Access to the LSM-81 via MODBUS-RTU Protocol</li> <li>• #-Command-Mode Used as SMS gateway</li> <li>• None no functionality of the interface</li> </ul>
COM port serial parameter settings	
Baudrate	Baud rate of the interface between 300 – 57600 bit/s
Databit	The number of the Data bits (5-8)
Parity	<p>Parity settings:</p> <ul style="list-style-type: none"> <li>• None: No Parity</li> <li>• Even: Even Parity</li> <li>• Odd: Odd Parity</li> </ul>
Handshake control	<p>Functions of the hardware handshake:</p> <ul style="list-style-type: none"> <li>• CTS: The CTS-line output will be set to "stop" by the LSM if not more data can be received via the interface. This setting must also be used for 3-wire operation (TxD, RxD and GND only)</li> <li>• CTS/RTS: Same as "CTS" with the difference that the LSM-81 can "stop" the transmission of the data via the RTS-line. Use only if hardware handshake is necessary and connected.</li> <li>• CTS line simulates DCD In this mode the CTS output simulates a DCD-line (Data Carrier Detect) if needed for elderly RTUs/PLCs.</li> </ul>
DCD sim pre-set time	Only when DCD simulation is active: time before data is sent where the CTS line is active
DCD sim post delay time	Only when DCD simulation is active: shows the time the CTS line should stay active after the last data byte was sent

Configuration Point	Description
COM port serial parameter settings	
Mode	<p>Menu to choose the layer 1 protocol:</p> <ul style="list-style-type: none"> <li>• Timeout: As soon as the interface receives the first byte, the timeout time will be set to the configured value. Each additional byte will top up the value of the timeout time to this value. If no more bytes are received via the interface, the transmission is terminated after the timeout time is expired and the LSM-81 processes the set of data. This mode is needed for MODBUS.</li> <li>• CR/LF: Characters are "collected" until a CR (Enter key) is detected. Then the received characters are processed. &lt;LF&gt;-characters are ignored. The dataset via the interface is terminated by sending &lt;CR&gt;&lt;LF&gt;. In this mode manual typing is possible to e.g. send SMS in #command via a terminal program.</li> <li>• 3964R: The interface communicates in 3964R protocol (protocol used for Siemens PLCs)</li> </ul>
Timeout	<p>The time after which the serial datagram is treated as complete in Timeout mode if no further characters are received.</p> <p>Any change in the serial interface baud rate will pre-set this value to ten times a character length.</p>

## 8.2 IP application interface

The IP application interface is an additional data interface (similar to the serial interfaces) which can use IP as communication method. It can be used to pass on data structures designed for serial interfaces via the IP link.

To ease things up: The IP application interface has the same function as a serial interface with the only difference that the physical connection is not a cable but an IP connection.

### LSM-81 configuration panel

Funk-Electronic Piciorgros GmbH - LSM-81 Stoermelder

**Login: partner**  
Logout

**Device**

- Common
- COM interface
- IP application interface
- Access
- Internal clock

**GSM / LTE**

**IP settings**

**RTU features**

**Service**

IP Application Interface status

Interface status CONNECTED to 0.0.0.0:0

IP Application Interface configuration

Port Operating mode

- Local: Modbus
- #-command mode
- None

IP interface settings

IP protocol

- Off
- UDP
- TCP Server
- TCP Client
- SIG-810

Listening port (UDP/TCP server) 5000

IP of receiver device (SIG-810,UDP/TCP client) 0.0.0.0

Port of receiver device (SIG-810,UDP/TCP client) 0

Reset    Apply

Configuration point	Description
IP Application Interface status	
Interface status	If an IP application interface is interconnected with a remote station, the IP address and the port of the remote station are shown here.
IP Application Interface configuration	
Port operating mode	<p>Menu to choose the operating mode of the interface:</p> <ul style="list-style-type: none"> <li>• Local: Modbus Access to the LSM-81 via MODBUS-RTU protocol</li> <li>• #-Command-Mode Used as SMS-Gateway</li> <li>• None No functionality of the interface</li> </ul>
IP Interface settings	
IP Protocol	<p>The interface can function in the following modes:</p> <ul style="list-style-type: none"> <li>• Off: Interface is deactivated</li> <li>• UDP: Interface interchanges data via UDP</li> <li>• TCP Server: Interface is used as TCP-server – the communication partner has to set up a TCP connection to the configured port of the LSM-81. Data can be sent and received via this TCP connection.</li> <li>• TCP Client: The LSM-81 sets up a TCP connection on its own to a specific IP address and port. Data packets can be sent and received via this TCP connection.</li> </ul>
Listening Port	<p>Only with "UDP" and "TCP server"</p> <p>"UDP" – the LSM-81 expects incoming UDP packets on this port</p> <p>"TCP server" – the LSM expects the incoming TCP connection on this port</p>
IP of receiver device	<p>Only with "UDP" and "TCP server"</p> <p>"UDP" – the LSM-81 sends out data to this IP address</p> <p>"TCP client" – LSM-81 tries to establish a TCP connection to this IP address</p>
Port of receiver device	<p>Only with "UDP" and "TCP server"</p> <p>"UDP" – LSM-81 sends out data to this port</p> <p>"TCP client" – the LSM-81 tries to establish a TCP connection to this port</p>

### 8.3 SMS Gateway (#-Command-Mode)

The LSM-81 can function as an SMS gateway for a connected device to easily send and receive SMS. The #-command mode is used via the serial interface or the IP application interface.

An SMS can be sent by using the syntax:

```
#T[Phone number]#[Text]
```

The command

```
#T+4917212345678#Hello World
```

sends out an SMS with the text "Hello World" to the number +4917212345678.

Phone numbers have to be entered in international format, the German number "0172/12345678" will be entered as "+4917212345678".

An SMS received by the LSM-81 will be handed to the interface in the same format:

```
#T[Phone number sender]#[Text]
```

## 8.4 Device Information and Security

Under the menu "Device" → "Common" general information of the LSM-81 can be found like serial number or software version. Furthermore, a device name can be determined here which will be shown in e.g. alarm SMS. The name can be the name of the site or the location of the device.

The device name will also be displayed in the header of the website.

Under "Security" a configuration protection can be activated. Once active, device configuration or transmissions of PicoLogo applications can only be transmitted to the LSM, if the device is set to "Default-IP-Mode" (to enable this mode the button in the little hole in the back of the device has to be pressed for one second until the OK-LED flashes. The device is now set to IP address 192.168.0.199).

Alternatively, the protection can be deactivated temporarily here before the transmission of a new configuration or a PicoLogo application.

The screenshot displays the LSM-81 configuration panel. The title bar reads "LSM-81 configuration panel" and "Funk-Electronic Piciorgros GmbH - LSM-81 Stoermelder". On the left, a navigation menu is shown with the following items: "Login: user" (with a "Logout" button), "Device" (highlighted with a red arrow), "Common", "COM interface", "IP application interface", "Access", "Internal clock", "GSM / LTE", "IP settings", "RTU features", and "Service". The main content area is divided into two sections: "Device information" and "Security". The "Device information" section lists: Serial number (21031), Software Version (1.01), Hardware Version (1), and Device name (LSM-81 Stoermelder). The "Security" section has a toggle for "Config protection when not in default IP mode" set to "Off", with "Reset" and "Apply" buttons below it.

Device information	
Serial number	21031
Software Version	1.01
Hardware Version	1
Device name	LSM-81 Stoermelder

Security	
Config protection when not in default IP mode	<input checked="" type="radio"/> Off <input type="radio"/> On
<input type="button" value="Reset"/> <input type="button" value="Apply"/>	

## 8.5 Setup of Ethernet Address

Under the menu "IP settings" → "Ethernet" the IP address of the ethernet port as well as the netmask can be configured.

Additionally, a gateway address can be configured if e.g. an LSM-81 is connected via LAN and should have access to other devices or the internet via a router (to e.g. set the time via SNPT).

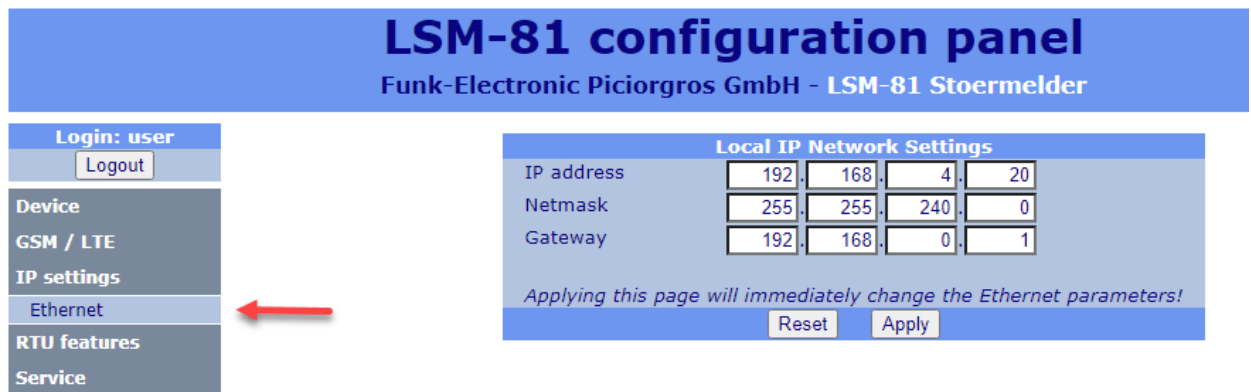

**LSM-81 configuration panel**  
Funk-Electronic Piciorgros GmbH - LSM-81 Stoermelder

Login: user  
Logout

Device  
GSM / LTE  
IP settings  
Ethernet  
RTU features  
Service

**Local IP Network Settings**

IP address	192	168	4	20
Netmask	255	255	240	0
Gateway	192	168	0	1

Applying this page will immediately change the Ethernet parameters!

Reset Apply

By default, the IP address is 192.168.0.199/20.

## 8.6 Other Configuration Options

### 8.6.1 Changing the password

Under the menu "Service " → "Manage passwords" the password to access the webservice can be changed for "user".

The screenshot displays the LSM-81 configuration panel. At the top, it reads "LSM-81 configuration panel" and "Funk-Electronic Piciorgros GmbH - LSM-81 Stoermelder". On the left, a navigation menu is shown with the following items: "Login: user" (with a "Logout" button), "Device", "GSM / LTE", "IP settings", "RTU features", "Service", "Contact", "Manage passwords" (highlighted with a red arrow), "Configuration", "Restart", "Registers", and "Eventlogger". On the right, the "Manage passwords" section is visible, titled "Change own password". It contains two input fields: "New Password" and "Repetition". Below these fields are two buttons: "Reset" and "Apply".

The new password has to be entered twice. After clicking apply the new password is valid starting with the next login.

**If the password is lost the device can be reset to delivery condition where the default password is "user"!**

### 8.6.2 Configuration of the Loggers and the Device Options

Under the menu "Service" → "Configuration" the loggings and device features can be configured:

## LSM-81 configuration panel

Funk-Electronic Piciorgros GmbH - LSM-81 Stoermelder

<div style="background-color: #4a7ebb; color: white; padding: 2px;">Login: user</div> <div style="background-color: #4a7ebb; color: white; padding: 2px; text-align: center;">Logout</div> <div style="background-color: #4a7ebb; color: white; padding: 2px;">Device</div> <div style="background-color: #4a7ebb; color: white; padding: 2px;">GSM / LTE</div> <div style="background-color: #4a7ebb; color: white; padding: 2px;">IP settings</div> <div style="background-color: #4a7ebb; color: white; padding: 2px;">RTU features</div> <div style="background-color: #4a7ebb; color: white; padding: 2px;">Service</div> <div style="background-color: #4a7ebb; color: white; padding: 2px;">Contact</div> <div style="background-color: #4a7ebb; color: white; padding: 2px;">Manage passwords</div> <div style="background-color: #4a7ebb; color: white; padding: 2px;">Configuration </div> <div style="background-color: #4a7ebb; color: white; padding: 2px;">Restart</div> <div style="background-color: #4a7ebb; color: white; padding: 2px;">Registers</div> <div style="background-color: #4a7ebb; color: white; padding: 2px;">Eventlogger</div>	<div style="background-color: #4a7ebb; color: white; padding: 2px; text-align: center;">Protocol Logger Configuration</div> <p style="margin: 0;">Order of logger output    <input type="radio"/> Oldest first <input checked="" type="radio"/> Latest first</p> <div style="background-color: #4a7ebb; color: white; padding: 2px; text-align: center;">Feature activation</div> <table style="width: 100%; border-collapse: collapse;"> <tr> <td style="width: 50%;">I/O</td> <td style="width: 50%;">Enabled</td> </tr> <tr> <td>SMS Gateway</td> <td>Enabled</td> </tr> <tr> <td>PicoLogo</td> <td>----</td> </tr> <tr> <td>Activation key</td> <td><input style="width: 100%;" type="text"/></td> </tr> <tr> <td>Key checksum</td> <td>63362</td> </tr> </table> <div style="background-color: #4a7ebb; color: white; padding: 2px; text-align: center;">UDP logging parameters (All 0 = Off)</div> <p style="margin: 0; font-size: small;"><i>Changing this parameters requires a device restart!</i></p> <table style="width: 100%; border-collapse: collapse;"> <tr> <td style="width: 60%;">Logger IP address</td> <td style="width: 10%;"><input style="width: 20px;" type="text"/> 0</td> <td style="width: 10%;"><input style="width: 20px;" type="text"/> 0</td> <td style="width: 10%;"><input style="width: 20px;" type="text"/> 0</td> <td style="width: 10%;"><input style="width: 20px;" type="text"/> 0</td> </tr> <tr> <td>Logger port</td> <td colspan="4"><input style="width: 100%;" type="text"/> 0</td> </tr> </table> <div style="text-align: right; margin-top: 10px;"> <input type="button" value="Reset"/>    <input type="button" value="Apply"/> </div>	I/O	Enabled	SMS Gateway	Enabled	PicoLogo	----	Activation key	<input style="width: 100%;" type="text"/>	Key checksum	63362	Logger IP address	<input style="width: 20px;" type="text"/> 0	<input style="width: 20px;" type="text"/> 0	<input style="width: 20px;" type="text"/> 0	<input style="width: 20px;" type="text"/> 0	Logger port	<input style="width: 100%;" type="text"/> 0			
I/O	Enabled																				
SMS Gateway	Enabled																				
PicoLogo	----																				
Activation key	<input style="width: 100%;" type="text"/>																				
Key checksum	63362																				
Logger IP address	<input style="width: 20px;" type="text"/> 0	<input style="width: 20px;" type="text"/> 0	<input style="width: 20px;" type="text"/> 0	<input style="width: 20px;" type="text"/> 0																	
Logger port	<input style="width: 100%;" type="text"/> 0																				

Configuration Point	Description
Protocol Logger Configuration	
Order of logger output	Determines the display order for the event logger. By default, "Latest first" is set.
Feature Activation	
Lists the device options and their activation status. Possible conditions are: <ul style="list-style-type: none"> <li>• Enabled: The Feature is permanently active</li> <li>• ----: The Feature is not active</li> <li>• [Remaining time]: A trial license is active; the remaining usage period is displayed.</li> </ul>	
I/O	This feature activates the binary and analog inputs and outputs as well as the possibility of operating with expansion modules.
SMS Gateway	IP – SMS – Gateway: Using the LSM-81 for SMS remote polling of an MDP-810 (future feature)
PicoLogo	Enables the execution of PicoLogo application in this device.
Activation key	An activation key for additional features or trial licenses can be added here
Key checksum	This value may be requested by the manufacturers' support team.
UDP logging parameters	
Enables the activation of the device logging using the IPLogger via UDP. UDP logging uses less resources than TCP logging and it is recommended to use when a device is logged over a longer period of time for service reasons. After changing the parameters, the LSM-81 has to be restarted.	
Logger IP address	IP address of the PC which runs the IP logger. The value 0.0.0.0 turns off the UDP logging.
Logger port	Configures the UDP port, the IP logger "listens" to. The value 0 turns off the UDP logging.

### 8.6.3 Restart and setting back to factory default

Under the menu "Service" → "Restart" the device can be restarted or be set back to default factory configuration:



### 8.6.4 Event Logger

The event logger saves device events like restarts, registration to the or loss of network, triggered alarms, acknowledgements of alarm and many more.

Up to 650 events including time stamp are displayed. Once 650 events are saved, the last event will be deleted for every new event occurring.



## 9 PicoLogo® Application Plattform

PicoLogo® is a user-friendly application platform and can be used to:

- Combine integrated I/Os with logical functions
- Send SMS notifications via complex input conditions
- Integrate different control and monitor functions

The graphical PicoLogo editor is needed to create such applications.

### 9.1 PicoLogo-Configuration

## LSM-81 configuration panel

Funk-Electronic Piciorgros GmbH - LSM-81 Stoermelder

<div style="background-color: #4a7ebb; color: white; padding: 2px;">Login: partner</div> <div style="text-align: right; padding: 2px;"><input type="button" value="Logout"/></div> <div style="background-color: #4a7ebb; color: white; padding: 2px;">Device</div> <div style="background-color: #4a7ebb; color: white; padding: 2px;">GSM / LTE</div> <div style="background-color: #4a7ebb; color: white; padding: 2px;">IP settings</div> <div style="background-color: #4a7ebb; color: white; padding: 2px;">RTU features</div> <div style="background-color: #4a7ebb; color: white; padding: 2px;">PicoLogo</div> <div style="background-color: #4a7ebb; color: white; padding: 2px;">Run switch / Status </div> <div style="background-color: #4a7ebb; color: white; padding: 2px;">Contact table</div> <div style="background-color: #4a7ebb; color: white; padding: 2px;">Parameters</div> <div style="background-color: #4a7ebb; color: white; padding: 2px;">Service</div>	<div style="background-color: #4a7ebb; color: white; padding: 2px; text-align: center;">PicoLogo run switch</div> <div style="padding: 2px;">PicoLogo mode <input type="radio"/> Stop <input checked="" type="radio"/> RUN</div> <div style="background-color: #4a7ebb; color: white; padding: 2px; text-align: center;">PicoLogo status</div> <div style="padding: 2px;">PicoLogo state RUNNING No errors</div> <div style="background-color: #4a7ebb; color: white; padding: 2px; text-align: center;">PicoLogo information</div> <div style="padding: 2px;">PicoLogo version 2.03 Required by program: 2.00</div> <div style="padding: 2px;">Device ID: 5000 ID of program: 5000</div> <div style="padding: 2px;">Program name: mse_lsm81_test Compile date: 24.06.24 - 09:19:59 Load date: 24.06.24 - 09:20:07</div> <div style="padding: 2px;">Used blocks: 23 (9%) Used space: 60 (5%)</div> <div style="background-color: #4a7ebb; color: white; padding: 2px; text-align: center;">Erase program:</div> <div style="padding: 2px;"><i>To delete the PicoLogo program in the device, type 'Delete' into the text field and press apply.</i> Type 'Delete' here <input style="width: 100px;" type="text"/></div> <div style="text-align: right; padding: 2px;"><input type="button" value="Reset"/> <input type="button" value="Apply"/></div>
---	--

Configuration Point	Description
<b>PicoLogo Run Switch</b>	
PicoLogo mode	<ul style="list-style-type: none"> <li>• STOP: An existing PicoLogo program in the device is not running</li> <li>• RUN: An existing PicoLogo program in the device is running</li> </ul> <p>The condition displayed here is power failure protected.</p>
<b>PicoLogo Status</b>	
PicoLogo state	Displays the current condition of the PicoLogo program within the device and shows failures (if any)
<b>PicoLogo Information</b>	
PicoLogo version	The program version of the PicoLogo Software within the LSM-81
Required by program	Required PicoLogo Version needed by the program within the device. In case the device version is older than the one required by the device, the application cannot run. In this case a firmware update of the LSM-81 is needed.
Device ID	Device-ID of the LSM-81
ID of program	Device ID for which the compiled program loaded into the device has been compiled. Must match the real device ID to execute the program.
Program name	File name of the PicoLogo program loaded into the device
Compile Date	Displays the date when the program was compiled
Load Date	Displays the date when the program was loaded into the LSM-81
Used Blocks	Amount and percentage of used PicoLogo blocks
Used Space	Amount of used words and percentual allocation of the memory space
<b>Erase Program</b>	
To delete the program in the device, the word "Delete" has to be entered in this field and "apply" has to be clicked afterwards.	

### 9.1.1 Contact Table

If SMS notifications are sent out through the PicoLogo program, the preconfigured recipient numbers (transmitted in the "SEND TEXT" blocks) are saved in the contact table.

This table can be edited in the web server and numbers can be changed. Without the need of restarting the device, the changes are automatically effective after clicking "Apply".

**LSM-81 configuration panel**  
Funk-Electronic Piciorgros GmbH - LSM-81 Stoermelder

**Login: partner**

**Device**  
GSM / LTE  
IP settings  
RTU features  
PicoLogo  
Run switch / Status  
**Contact table** ←  
Parameters  
Service

**PicoLogo contact table**

10 entries beginning with

ID	Type	Contact
1	TelNr.	+ <input type="text" value="4917208150815"/>

If the original PicoLogo program will be loaded into the device, the contact table will be overwritten with the numbers saved in the program.

### 9.1.2 Parameter Table

Optionally some PicoLogo blocks can transmit fixed parameters into the web server:

Gate Name (Label)	L22	Description (visible in web server)
Switch on delay (100ms steps)	30	

These values are displayed in the parameter table and can be changed any time during the execution of the PicoLogo program. Without the need of restarting the device, the changes are automatically effective after clicking "Apply".

## LSM-81 configuration panel

Funk-Electronic Piciorgros GmbH - LSM-81 Stoermelder

**Login: partner**  
[Logout](#)

**Device**

- GSM / LTE
- IP settings
- RTU features
- PicoLogo**
- Run switch / Status
- Contact table
- Parameters
- Service

PicoLogo parameter table		
ID	Description	Value
10 entries beginning with <input style="width: 50px;" type="text" value="1"/> <a href="#">Browse</a>		
1	Verzögerung A7	<input style="width: 100px;" type="text" value="30"/> [0 - 65535]
2		<input style="width: 100px;" type="text"/>
3		<input style="width: 100px;" type="text"/>
4		<input style="width: 100px;" type="text"/>
5		<input style="width: 100px;" type="text"/>
6		<input style="width: 100px;" type="text"/>
7		<input style="width: 100px;" type="text"/>
8		<input style="width: 100px;" type="text"/>
9		<input style="width: 100px;" type="text"/>
10		<input style="width: 100px;" type="text"/>
		<input type="button" value="Reset"/> <input type="button" value="Apply"/>

If the original PicoLogo program will be loaded into the device, the parameter table will be overwritten with the parameters saved in the program.

## 10 Troubleshooting and Administration

### 10.1 Saving and restoring a configuration

The LSM-81 configuration can be stored on a PC as a backup. This file can also be used to load the same configuration into other LSM-81.

The "IPLoader" Software is needed here.

#### 10.1.1 Downloading the configuration of an LSM-81

To read out the configuration of an LSM-81, IPLoader has to be started. IPLoader has to be set to "IP Network" and the IP address of the LSM-81 has to be entered:

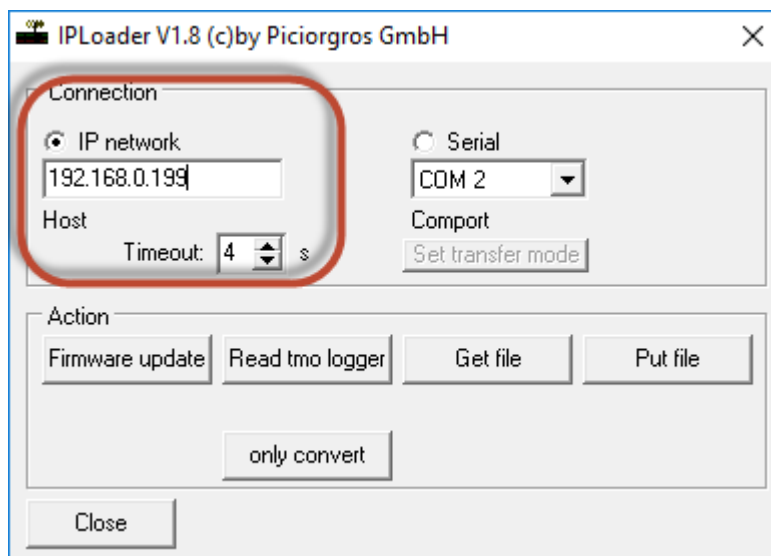

Click "Get file"

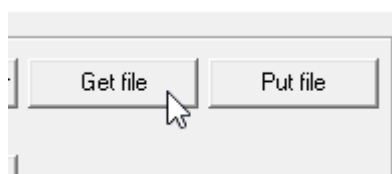

Choose a location on the PC, where the file should be saved with the filename "config.tmo"

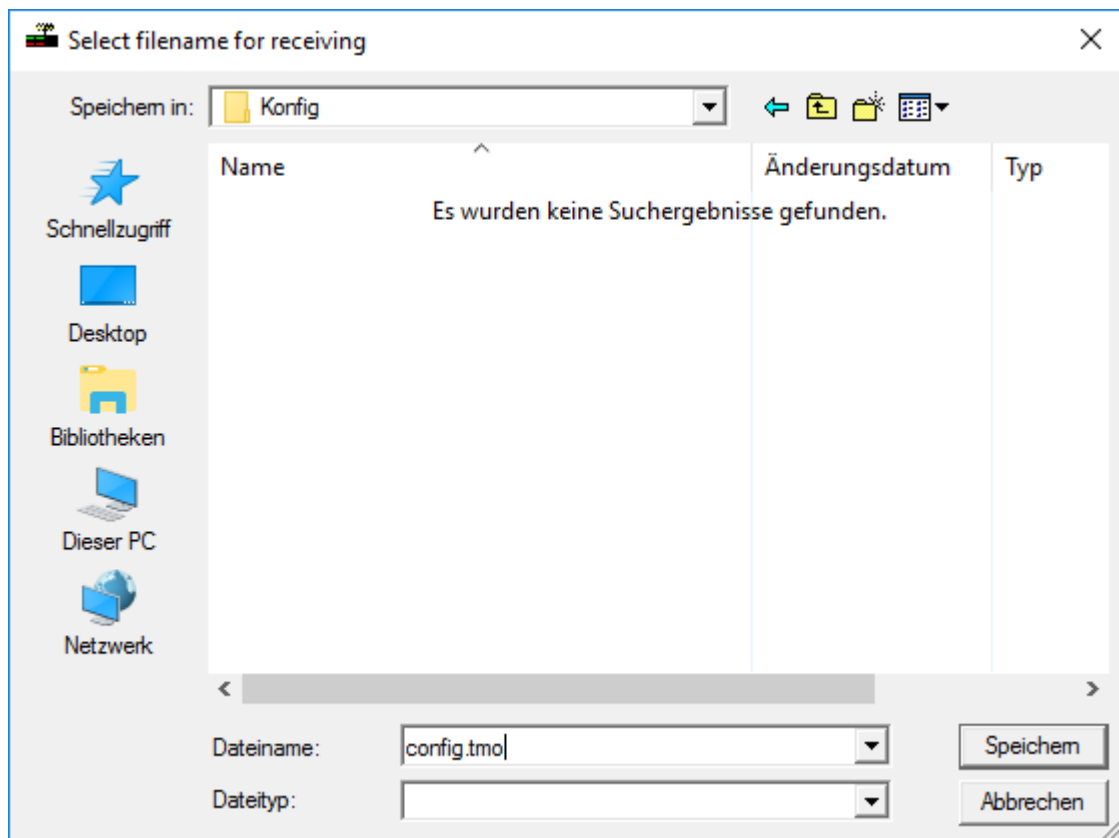

A progress bar will appear to indicate that the transfer is still running

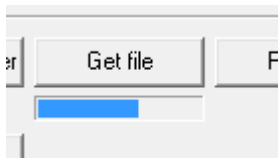

Once done this message will appear:

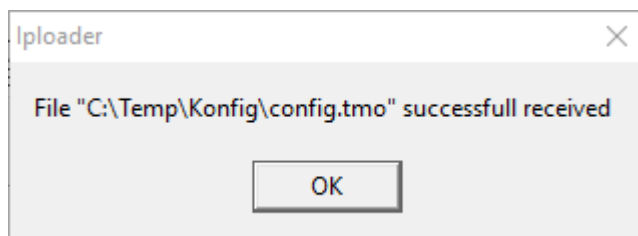

The file name can be changed afterwards. A name should be used that clearly identifies the file and differentiates it from other config files. The file extension has to remain “.tmo”.

Name	Änderungsdatum	Typ	Größe
 Cataula Water Tank.tmo	29.03.2017 11:52	TMO-Datei	234 KB

### 10.1.2 Restoring a Configuration

A configuration file can be uploaded into any LSM-81, as long as hardware versions match. This is how the same configuration can be uploaded into multiple LSM or how a configuration is restored in case some misconfigurations were made.

In case the configuration is cloned or used as master, some parameters like device name and SIM PIN have to be adjusted accordingly.

To restore the configuration, click “Put File”:

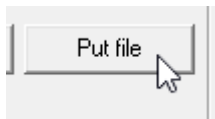

Identify the configuration file:

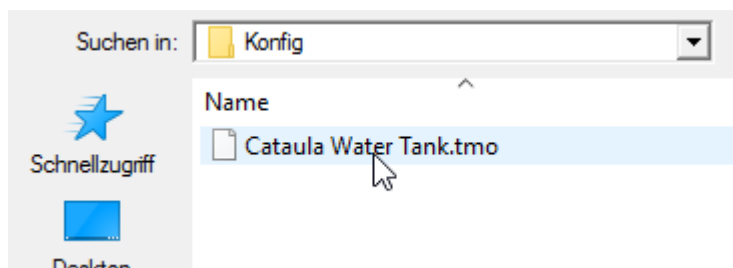

A progress bar will appear to indicate that the transfer is still running



Once done this message will appear:

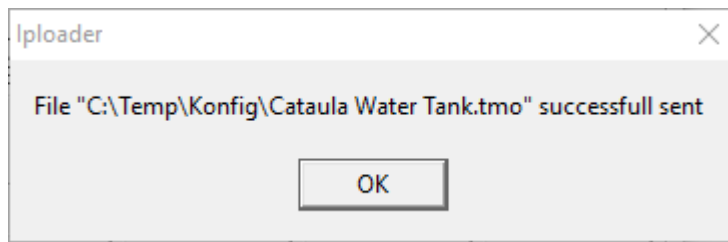

The LSM has to be restarted to accept the changes made.

## 10.2 Collecting Support Logs

If problems occur the support team may ask the user to send so called "IP-Logs". These logs give information on internal processes and the data flow of the LSM-81.

IP-Logs can be issued with the help of the IPLogger Software. An IP connection from the LSM to a PC (with IPLogger installed) is needed. **Because of the tremendous amount of data, the IPLogger should not be run over WiFi or another internet connection, because this could lead to an overflow of the TCP buffer of the LSM! In this case the logging should be performed via UDP.**

The IP address in the IPLogger needs to match the IP address of the LSM:

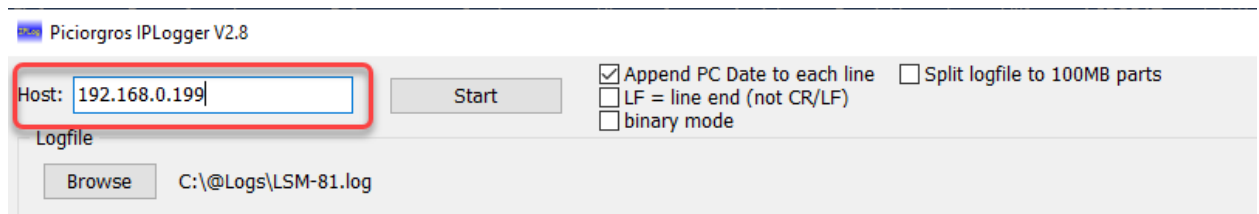

Determine the location and name under which the file should be saved:

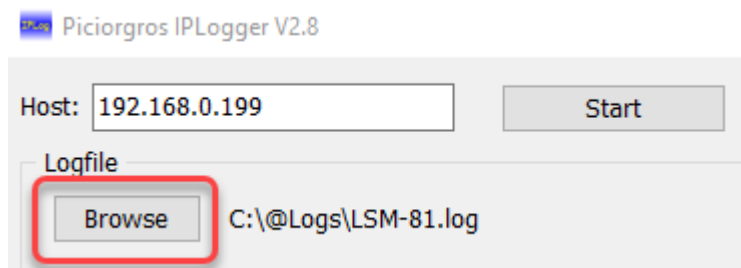

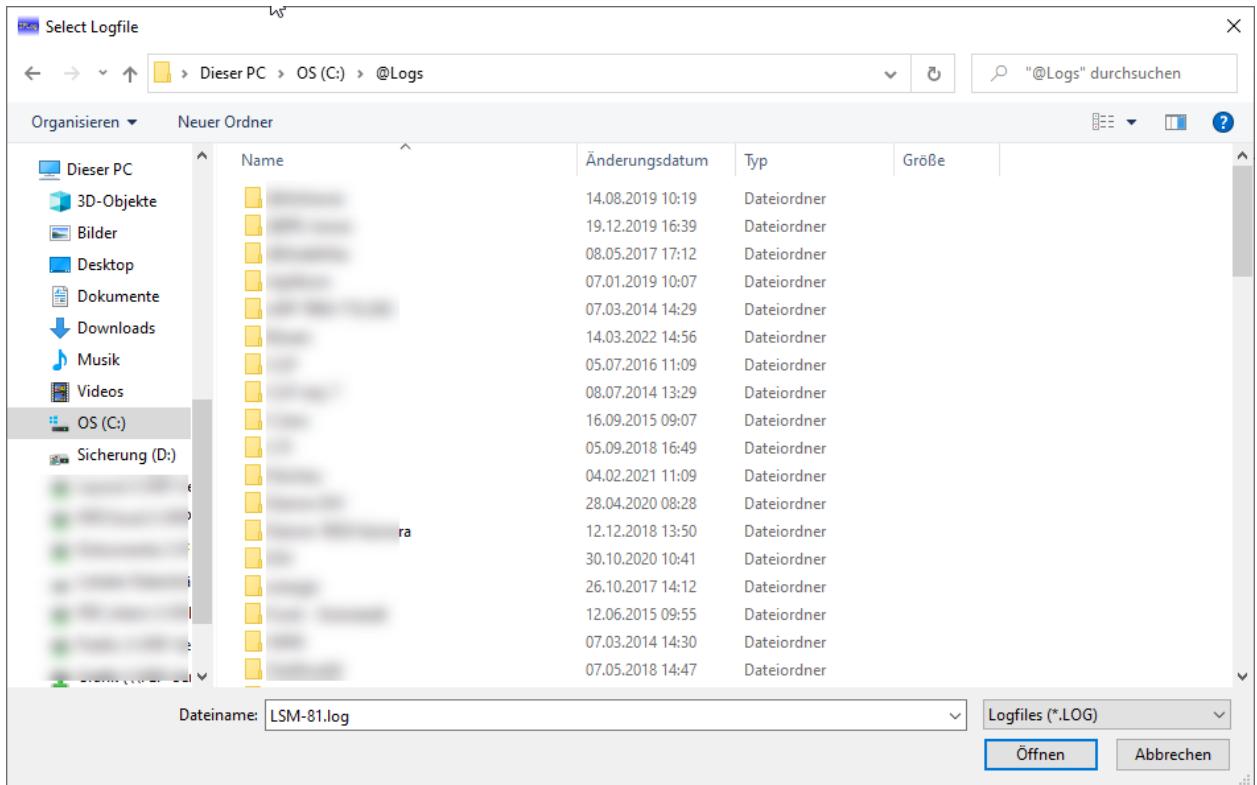

The file extension ".log" should not be changed!

Now the "Start" button can be clicked to start the log:

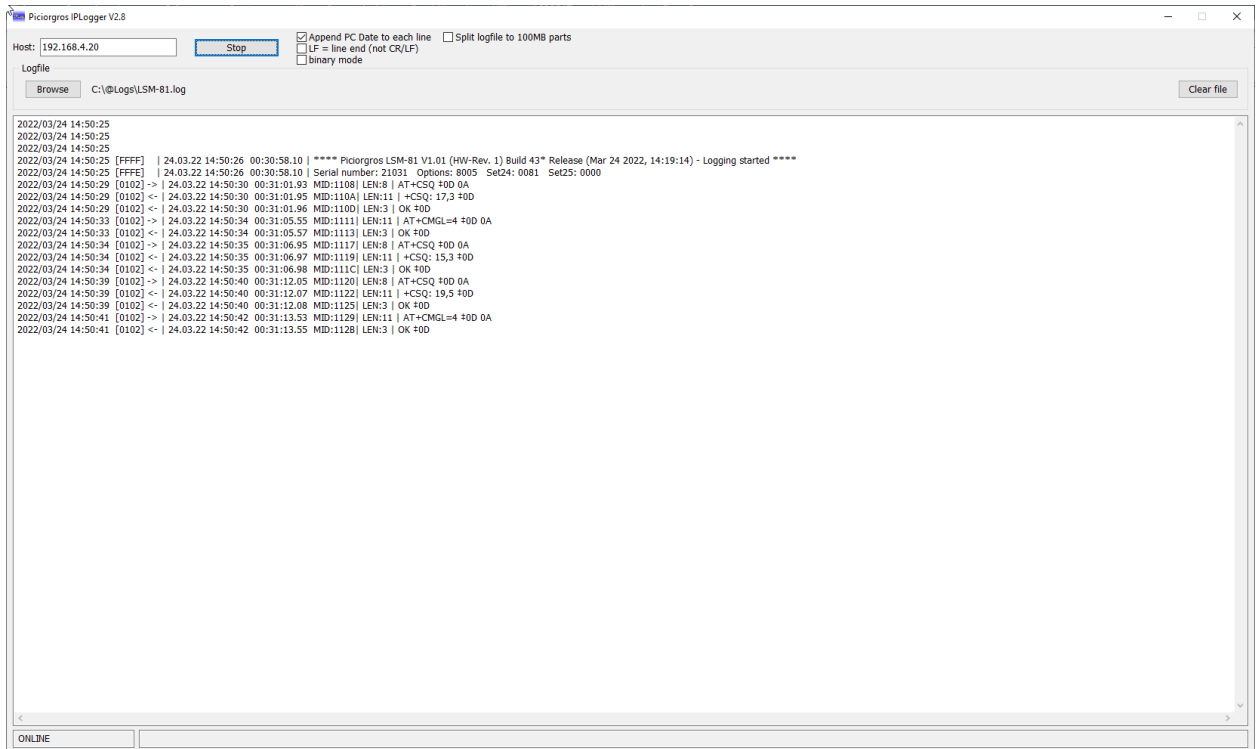

The logged data will appear in the IPLogger to indicate that the logger is active.

The logging can be stopped and started anytime. Even when the IPLogger is restarted, it will append the data to the existing file.

If the file should be deleted, please click "Clear File".

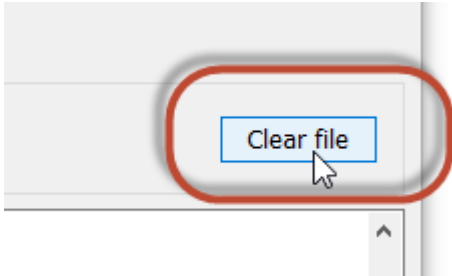

This can also be done spontaneously while the logging is active without stopping the IPLogger.

If the file needs to be sent to the support team, the file should be compressed as the file is quite big.

### 10.2.1 UDP Logging

For larger logs it is recommended to use UDP, as this method is more resource saving. Also, this method can be used in a network with greater latency like the internet.

The IP address of the PC as well as the port, to which the IPLogger "listens" to need to be [configured in the LSM](#).

The UDP port, on which the IPLogger messages should be received, needs to be adjusted to the format "UDP:Port" at the point where the IP address of the LSM shows the "Host".

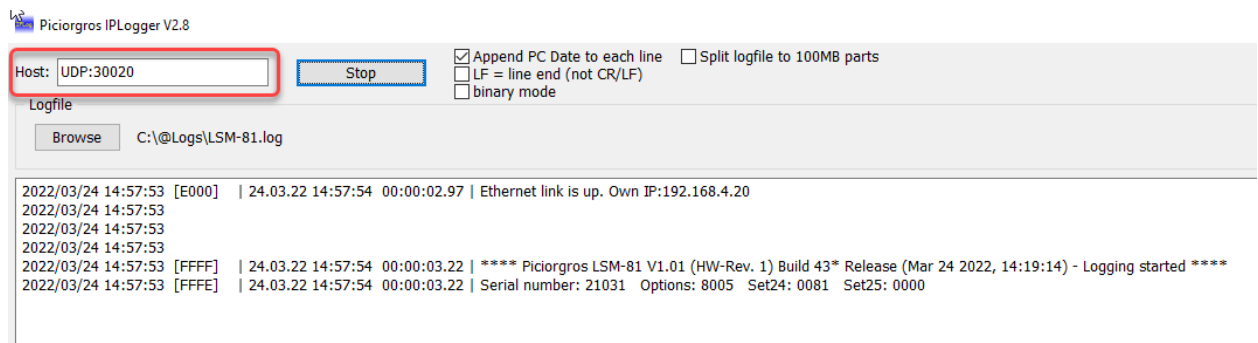

### 10.2.2 Automatic splitting of Log File

When a log is running over a longer period of time, it is recommended to split the file so that the file size does not get too large.

To enable this, the box "Split logfile into 100MB parts" has to be checked before clicking "start":

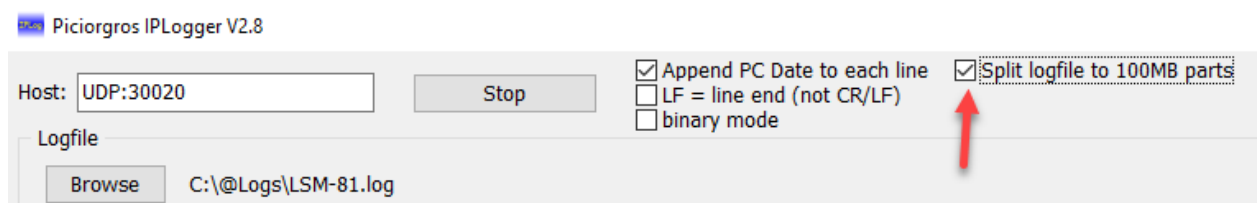

The IPLogger will now automatically split the file into 100 MB parts and saves the files with time stamp and file name.

## 10.3 Updating the Firmware

### 10.3.1 Preparation and Setup

To update the LSM-81 the following is needed:

- PC with Ethernet Connection
- ILoader Software
- Firmware file for the LSM-81

### 10.3.2 Update Procedure

The LSM-81 firmware is a file with the appendix “.pfo”. To update the firmware of the LSM-81, it has to be connected to a PC over the Ethernet interface.

The currently installed firmware version can be checked under "Device" → "Common"

The screenshot displays the 'LSM-81 configuration panel' interface. On the left is a navigation menu with categories: 'Login: user' (Logout), 'Device' (Common, COM interface, IP application interface, Access, Internal clock), 'GSM / LTE' (IP settings, RTU features, Service). A red arrow points to the 'Common' option under 'Device'. The main content area shows 'Device information' with fields: Serial number (21031), Software Version (1.01, highlighted with a red box), Hardware Version (1), and Device name (LSM-81 Stoermelder). Below this is the 'Security' section with a radio button for 'Config protection when not in default IP mode' (set to Off) and 'Reset'/'Apply' buttons.

A firmware with the same name can be loaded into the LSM-81, but the internal update process will not be initiated.

All settings and feature activations will be kept.

The IP address of the LSM-81 needs to be entered in the IPLoader in the field "IP network". Afterwards click on the button "Firmware update":

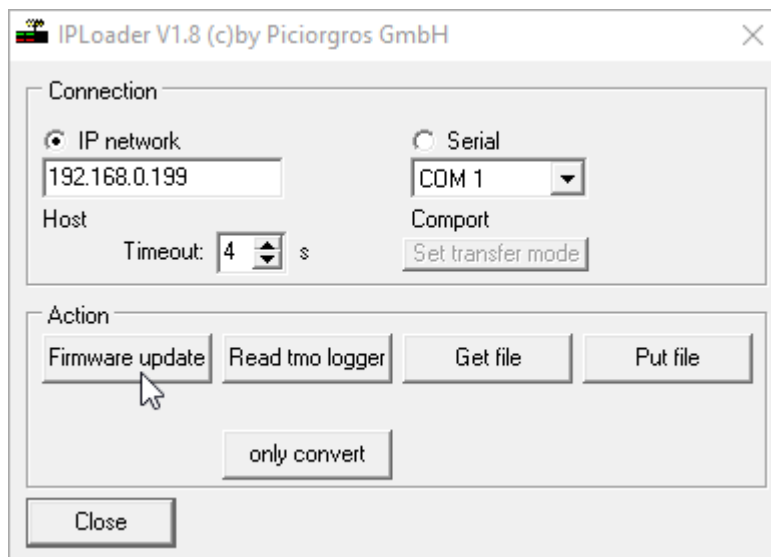

Now the firmware file has to be selected and opened:

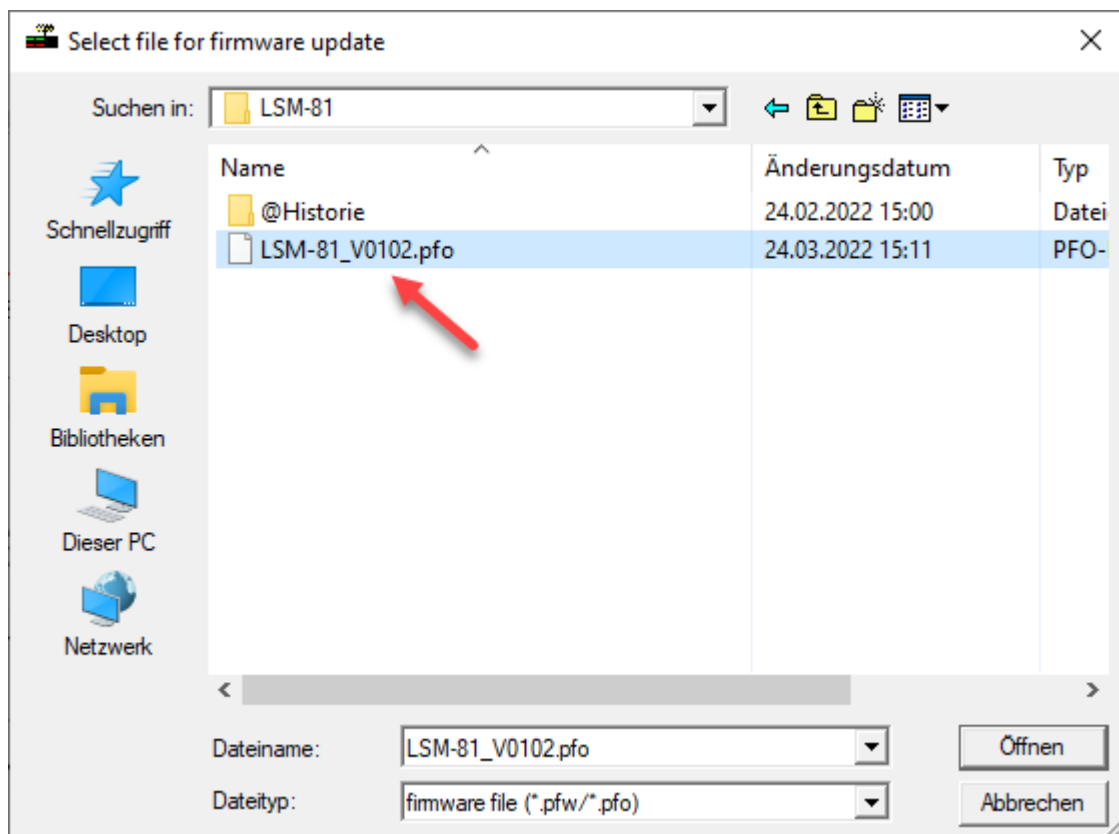

The IPLoader will now start the transfer to the LSM-81 and will indicate this process as follows:

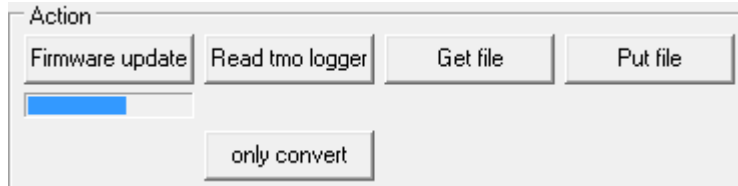

The internal update process will start right after the transmission. The "Link" LED of the ethernet port will go off shortly after about 30 seconds.

### Important!

During the internal update process the **POWER SUPPLY OF THE LSM-81 MUST NOT BE DISCONNECTED!** Otherwise, the LSM-81 cannot restart and has to be restored by Piciorgros or a service partner.



After the process is terminated, the LSM will automatically restart with the new firmware. The Link LED of the Ethernet port, as well as the OK LED, will illuminate. The firmware update was successful.

### 10.3.3 Multilingualism

A German and English Firmware version is available starting with firmware V1.10. The German firmware is labeled with "-DE..." and the English version with "-EN...".

The configuration of the device will remain even when the user switches between firmware versions.

The device will not perform and update, if the firmware version number does not change. This can be bypassed with the "\_AU"-version (Always update).

When switching between e.g. the English firmware version 1.10 to the German firmware version 1.10, the file "LSM-81\_V0110-DE\_AU.pfo" has to be used.

## 11 Technical Specifications

<b>GSM/LTE</b>	
Frequencies	GSM: 900 / 1800 MHz LTE: 800 MHz, 900 MHz, 1800 MHz, 2100 MHz, 2600 MHz
Antenna Connector	SMA connector (female)
SIM Card	Push-Pull card reader micro SIM, accessible from the left device side
<b>Alarm Features</b>	
Phone Book	Phone book with up to 25 entries plus one supervisor field
Alarm Blocks	24 binary and 16 analog alarm blocks with individual message text and configuration.  The binary alarm blocks can be activated using different input operations (AND, OR, XOR, Inverted)  The analog alarm blocks offer a scaling for the connected 0/4-20mA sensor and a configurable hysteresis.
<b>Inputs and outputs</b>	
Basic Unit	8 binary inputs (12-24V DC) 8 binary outputs (12-24V DC, 500mA, Open Collector PNP) 2 analog inputs (0/4-20mA)
Expansions	Up to 16 PEM expansion modules can be connected.  The first 24 binary inputs and outputs as well as the first 10 analog inputs can be used for the application of alarm blocks.
<b>Other Features</b>	
MMI	Controlling and polling of I/O's can be done using MMI commands via SMS. For the access protection a PIN number implemented. Additionally, the access can be limited to phone book entrants only.
OK Messages	Daily OK messages to selectable phone numbers are possible.
RTU functionality and remote access	The with addition of an MDP-810 radio server, up to 64 LSM-81 can be connected to a control system. The data transmission takes place over the cellular network.
PicoLogo	The application platform PicoLogo offers the creation and performance of logical processes to realize local control processes and other alarms.
Multilingualism	German and English Firmware available

<b>Interfaces</b>	
Serial Interface	RS-232 Interface (optional RS-422/485) for local access via MODBUS-RTU protocol or to be used as SMS gateway
Ethernet Interface	For the configuration of the LSM-81 via the embedded webserver as well as the access to the device via MODBUS/IP protocol
Expansion Port	To connect up to 16 I/O expansion modules (PEMs).
<b>Power Supply</b>	
Power Supply Voltage	12-24V DC, +/- 20%
Power Consumption	~ 130mA with Power Supply Voltage of 12V ~ 70mA with Power Supply Voltage of 24V The Power Supply Voltage has to provide 1A for a short amount of time (when sending towards the cellular network).
<b>Enclosure</b>	
Material	Anodized aluminum enclosure with metalized plastic side caps DIN rail mounting
Dimensions	80 x 108 x 62 mm (6 TE)
<b>Optional Equipment</b>	
<ul style="list-style-type: none"> <li>• Different antenna types</li> <li>• Power Supply PNT-230/12B with emergency power supply</li> <li>• PEM expansion modules for additional I/O's</li> </ul>	